

Solutions for long travel applications.

with or without Guide Troughs

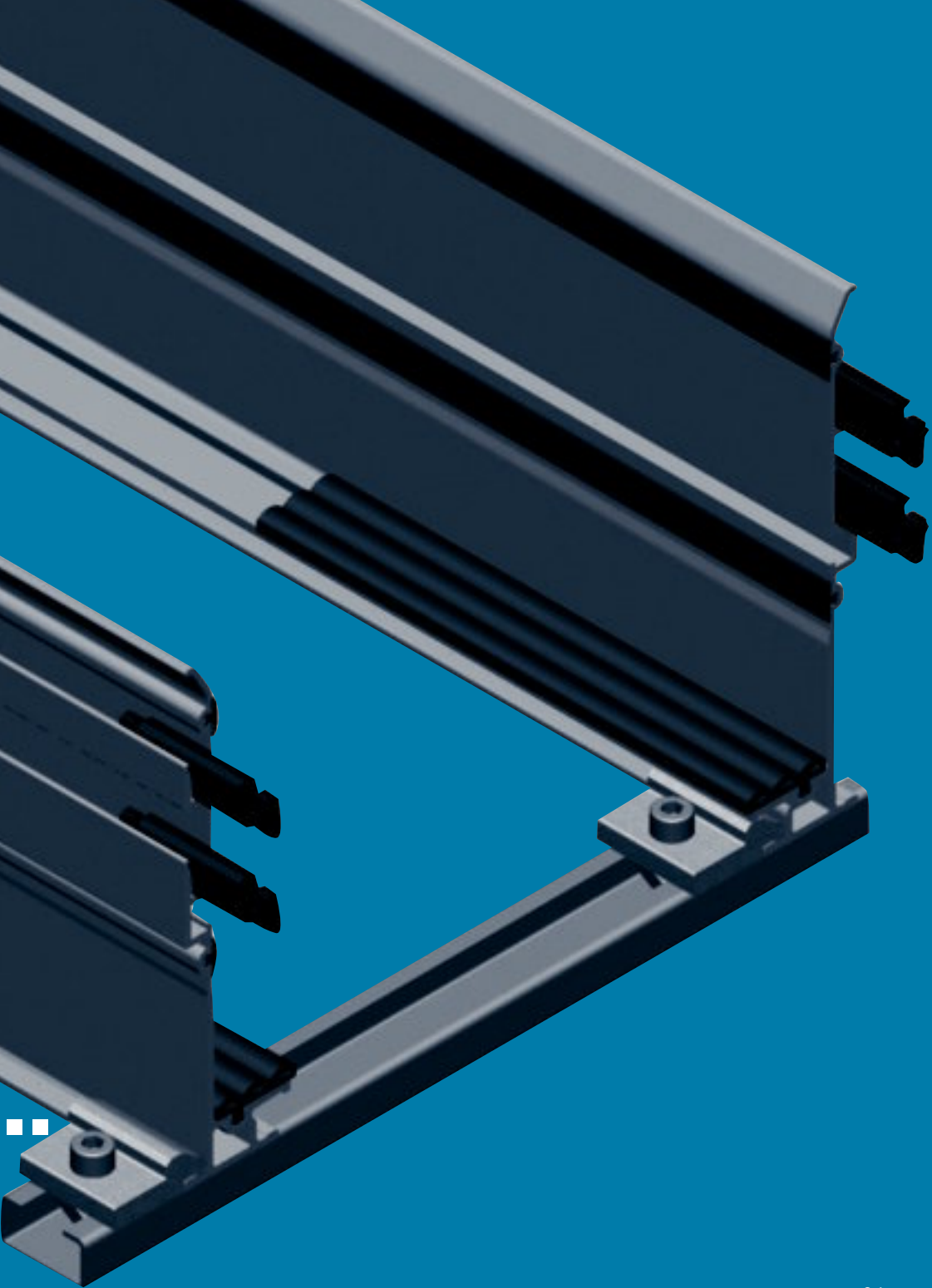

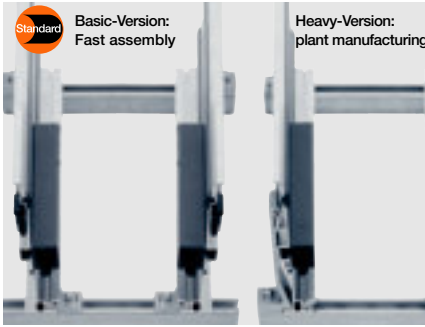

Aluminium "SuperTrough" - The igus® standard guide trough

- Very simple, modular assembly
 - Side-mounted glide strips for wear protection in high-speed
 - Corrosion resistant, seawater resistant aluminium profile
 - Flexible assembly - Fastening on substructure independent of profile lengths and butt joints
 - Plastic glide bar made of PE
 - Bottom clamp can be mounted -inside or outside- directly on the bottom or on the c-profile
 - Heavy duty brackets for safe connection also for rough applications
- from page 9.12

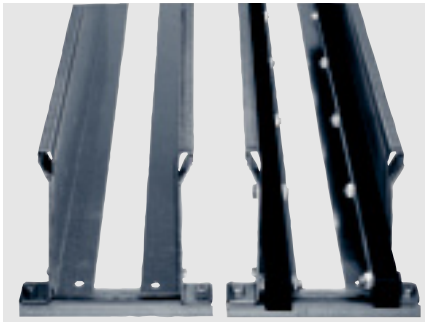

Steel guide trough - very stable and rugged for heavy duty applications

- Very stable and robust guide trough made of steel
 - Easy assembly with installation set
 - Big range, two piece design, adjustable to e-chain® width
 - Available in galvanized steel and stainless steel
 - Glide bar made of PE
- from page 9.42

Further Guide Troughs | Cost-effective troughs and support trays

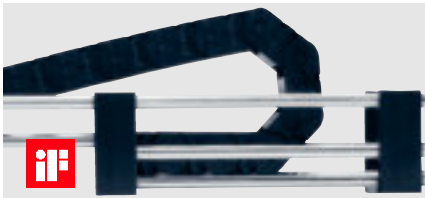

Tubular trough system RS - lets light and dirt through

- Resistant to dirt - wear debris falls through
 - More translucent than sheet metal constructions
 - Easy and fast assembly and low price
 - Easy and space saving delivery
- from page 9.66



Snap-in trough system SP - simple and cost effective

- Smaller than conventional troughs
 - Easy and fast assembly
 - No sharp metal edges in the internal area because of covered connectors
 - Low price because of easy assembly
- from page 9.68



For support of the lower run - Support tray tool kit

- Complete system, ready to install
 - No more costly self-made designs
 - Easy installation onto your machine, on profiles or wall-mount brackets
- from page 9.70



System P4 - rol e-chain®

800 m travels and more are possible and speed (up to 10 m/s), silent

- Smooth, shock free motion, running offset with split rollers
 - Energy efficient polymer rol e-chainsystem® reduce energy consumption by up to 57%
- ▶ from page 9.78



rol e-chain® - Rolling instead of gliding

Travels up to 800 m, speeds up to 6 m/s

- Major reduction in drive power to less than 25 % for moving the e-chain®
 - rol e-chain® is designed for applications with long travel lengths at high speed
- ▶ from page 9.86

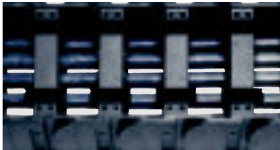

autoglide - Long travels without guide troughs

Travels up to 50 m, speeds up to 1,5 m/s

- autoglide e-chain® links are moulded and no additional parts are necessary
 - Very fast assembly times for long travels - No Guide Troughs required!
- ▶ from page 9.90



guidelok horizontal - upper run guide for long travels

Travels, unsupported up to 50 m possible

- Chips cannot get stuck between upper and lower run
 - Enormous increase of „self supporting“ length of e-chains®
- ▶ from page 9.96



guidelok slimline "F" - Safe vertical guidance NEW in this catalog

For e-chains® in high-speed rack feeders - up to 7 m/s and 10 m/s²

- No swinging of the e-chain®, high reliability through lever mechanism and guiding rails
 - No bouncing of e-chains® in vertical applications with horizontal dynamics
- ▶ from page 9.98



lbt flizz® - Enclosed plastic trough

Travels up to 120 m, speeds up to 8 m/s

- Applicable for moving and stationary control, ideal for all bus systems
 - Good for applications needing low weight and good corrosion resistance
- ▶ from page 9.100



micro flizz® - Small e-chains® in aluminum profile

ONE compact system for a secure guidance of power, data and air

- Maintenance-free alternative for busbar
 - Control via stationary switch cabinet possible
- ▶ from page 9.104





levichain - magnetic e-chainsystem® - it "floats"

Long travel possible without laying the e-chain® systems on top of each other

- Almost no abrasion and very low wear due to low-abrasion e-chain® links (without pin/bore connection) as well as almost contactless movement of the e-chain®
- ▶ from page 9.112

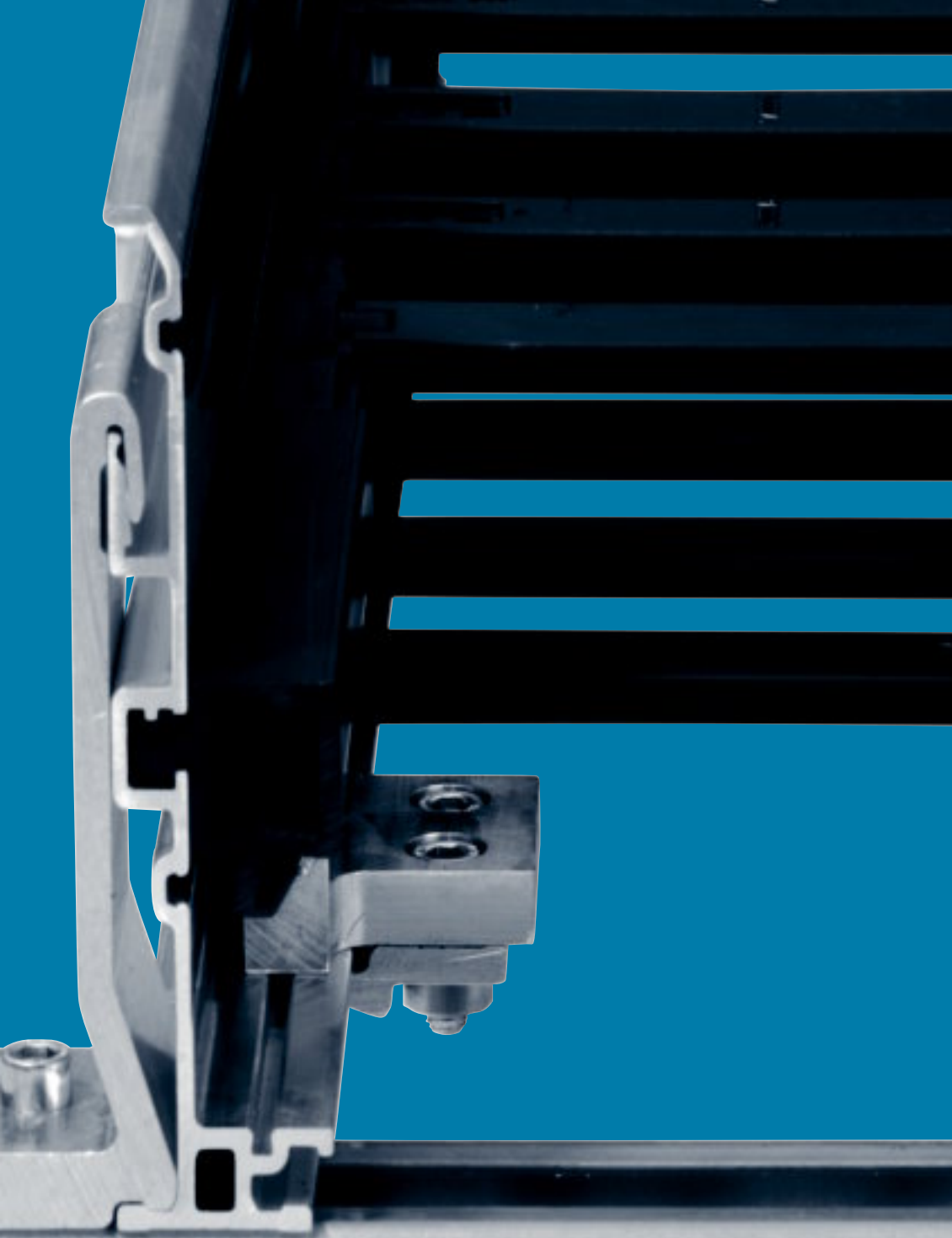



A detailed cross-sectional view of a Guide Trough System. The image shows a complex assembly of metal components. On the left, a dark, ribbed structure is visible. In the center, a vertical metal guide rail with a T-shaped profile is shown. To its right, a horizontal metal trough with a U-shaped profile is attached. Various fasteners, including bolts and nuts, are used to secure the components together. The background is a solid blue color.

Guide Trough Systems

Aluminum "SuperTrough" | Basic version - for general machinery



Basic version
▶ from page 9.20

Guide trough Series Part No.	Outer trough height H_{Ra} [mm]	Price index	Materials of side parts	Page
970.30.SL / 970.31.SL	77	● ● ●	Aluminum	9.20
970.30.SL / 970.32.SL	77	● ● ●	Aluminum	9.22
971.30.SL / 971.31.SL	87	● ● ●	Aluminum	9.24
972.02.30.SL / 972.02.31.SL	117	● ● ●	Aluminum	9.26
972.30.SL / 972.31.SL	117	● ● ●	Aluminum	9.28
972.30.SL / 972.32.SL	117	● ● ●	Aluminum	9.30
973.30.SL / 973.31.SL	144	● ● ●	Aluminum	9.32
974.30.SL / 974.31.SL	184	● ● ●	Aluminum	9.34
975.30.SL / 975.31.SL	236	● ● ●	Aluminum	9.38

Assembly kit for the basic version

The basic assembly kits are the standard for the super aluminum troughs. They can be fastened inside or outside and are recommended for most application areas. The basic clamping shoes are made of aluminum. The part numbers of the basic assembly kits can be found on the corresponding Super-Alu-Trough page.

Aluminum "SuperTrough" | Heavy-duty version - for rugged plant construction

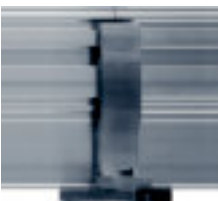

Heavy-Duty Version
▶ fom page 9.24

Guide trough Series Part No.	Outer trough height H_{Ra} [mm]	Price index	Materials of side parts	Page
970.30.SL / 970.31.SL	87	● ● ●	Aluminum	9.25
970.30.SL / 970.32.SL	117	● ● ●	Aluminum	9.27
972.30.SL / 972.31.SL	117	● ● ●	Aluminum	9.29
972.30.SL / 972.32.SL	117	● ● ●	Aluminum	9.31
973.30.SL / 973.31.SL	144	● ● ●	Aluminum	9.33
974.30.SL / 974.31.SL	184	● ● ●	Aluminum	9.35
975.30.SL / 975.31.SL	236	● ● ●	Aluminum	9.39

Assembly kit for the heavy-duty version

The heavy-duty version of the Super-Alu-Trough is differentiated only by the type of the assembly kit. The part numbers of the channel side plates, slide bars, etc., are the same as the basic model. The heavy-duty assembly kit consists of a rugged aluminum bracket, fastened outside on the guide trough. The heavy-duty assembly kits are recommended for plant construction and extreme application areas. The part numbers of these assembly kits can be found on the corresponding Super-Alu-Trough page.

Steel guide troughs | For harsh environments



ST Steel guide troughs
▶ from page 9.44

Guide trough Series Part No.	Outer trough height H_{Ra} [mm]	Price index	Materials of side parts	Page
92.30 / 92.31	70	● ● ●	Galvanized steel*	9.44
95.30 / 95.31	100	● ● ●	Galvanized steel*	9.46
99.30 / 99.31	100	● ● ●	Galvanized steel*	9.48
97.30 / 97.31	130	● ● ●	Galvanized steel*	9.50
93.30 / 93.31	130	● ● ●	Galvanized steel*	9.52
94.30 / 94.31	170	● ● ●	Galvanized steel*	9.54
96.30 / 96.31	220	● ● ●	Galvanized steel*	9.56
98.30 / 98.31	300	● ● ●	Galvanized steel*	9.58
90.30 / 90.31	480	● ● ●	Galvanized steel*	9.60
91.10 - 91.71**	48	● ● ●	Galvanized steel*	9.63

*Stainless steel on request **Steel guide troughs, one-piece

Tubular trough system RS | Lets debris through, and gives good visibility



RS Tubular trough
▶ from page 9.66

Guide trough Series Part No.	Outer trough height H_{Ra} [mm]	Price index	Materials of side parts	Page
92.70 / 92.71	90	● ● ●	Galvanized steel / Polymer	9.66
93.70 / 93.71	146	● ● ●	Galvanized steel / Polymer	9.67
95.70 / 95.71	126,3	● ● ●	Galvanized steel / Polymer	9.67

Snap-in trough system SP | Simple and cost effective



SP Snap-in trough
▶ from page 9.68

Guide trough Series Part No.	Outer trough height H_{Ra} [mm]	Price index	Materials of side parts	Page
91.930	55,5	● ● ●	Galvanized steel	9.68
92.930	76,6	● ● ●	Galvanized steel	9.68
93.930	138,6	● ● ●	Galvanized steel	9.69
95.930	106,6	● ● ●	Galvanized steel	9.69

Support tray | For support of the lower run



Support tray
▶ from page 9.70

Support tray Part No.	e-chain* width	Inner trough - width B_{Ri} [mm]	Outer trough - width B_{Ra} [mm]	Material	Page
S9.010/011.05.XXXX.0	.05 / .050	89	80	Steel, black	9.70
S9.010/011.07.XXXX.0	.07 / .070	114	105	Steel, black	9.70
S9.010/011.10.XXXX.0	.10 / .100	139	130	Steel, black	9.70
S9.010/011.15.XXXX.0	.15 / .150	185	175	Steel, black	9.70
S9.020/021.10.XXXX.0	.10 / .100	167	156	Steel, black	9.70
S9.020/021.15.XXXX.0	.15 / .150	217	206	Steel, black	9.70
S9.020/021.20.XXXX.0	.20 / .200	267	256	Steel, black	9.70
S9.020/021.25.XXXX.0	.25 / .250	317	306	Steel, black	9.70

XXXX = length 1000 or 2000 mm - for almost every Series E2/000, E4.1 and E6 e-chains* available

igus® guide troughs

Guide troughs are used for long travels, (travels from 5 to 12 m) and greater, depending on the e-chain® type. They allow to continue smooth, low-friction operation in these long-travel situations. If the e-chains® are installed in the center of the travel ("center-mounted"), they glide on themselves for half the travel. For the other half, we recommend glide bars, which are assembled in the trough and on which the e-chains® glide. igus® guide troughs are available from stock with these highly abrasion-resistant polymer glide bars, which perform well with igus® e-chains® regarding noise, abrasion and friction.



Various guide trough systems are available



igus® Support tray -
for support of the lower run ► page 9.70

Trough type

igus® offers guide troughs made of corrosion-resistant aluminum, steel, stainless steel, as well as tubes and insert troughs (with steel side plates). The trough type to be used depends on the application conditions and the requirements of the customer. We recommend the igus® standard super aluminum guide troughs.

Glide bars

Glide bars made of igulene are optimally matched to the e-chain® material and achieve the lowest values for friction, noise and wear. Glide bars must be used, if the fixed point is in the center of the travel. It means: Use half of the guide trough with glide bars and the other half of the guide trough without glide bars.

Delivery condition

The troughs are delivered in 2 meter sections. Special lengths up to 6 m are possible. The left and right side parts are installed on location with the appropriate distance - depending on the width of the e-chain®. The necessary width is shown by the dimension B_{PI} on the guide trough pages. The e-chain® sides can be linked with the base through screwing, welding or a special igus® installation set. The fixation module for the igus® Super-Alu-Trough is a quick fix for mounting the stationary end of an e-chain® with a KMA-mounting bracket. With this module a fast and easy mounting onto the Super-Aluminum-Trough is possible without any drilling ► page 9.16.

Own production

The dimensions quoted in this chapter are for design and installation. They apply exclusively to igus® guide trough systems. If a user of igus® e-chains® produces own designs, the manufacturing and installation dimensions for the necessary guide trough must be obtained from igus®. This applies in particular to the use of one-piece guide troughs and the play between guide trough and e-chain®, depending on chain type, chain length, size bending radius and tolerance of the moving end and the base. One must be particularly careful here, since a function-compatible setting during installation and a subsequent adjustment is not possible for such guide troughs.



Trough without glide bars -
e-chain® glides on e-chain®



Trough with glide bars -
e-chain® glides on glide bars



Center mounted: 1/2 Travel with glide
bars - 1/2 Travel without glide bars

For long travels, the upper run of the igus® e-chains® rests on the lower run. The upper run glides partially on the lower run and partially at the same height on a glide bar. The diagrams below show this. For lateral guidance, a Guide Trough is necessary. If the stationary mounting bracket and the fixed end of the cables and hoses can be placed **in the center**, the e-chain® length is calculated as follows: $L_k = S/2 + K$. The shortest e-chain® length is attained by the axial feeder module. The length of the e-chain® then corresponds to about half the travel distance. Depending on the technical data and the selected e-chain®, the mounting point of the moving end of the e-chain® must be lowered on some units. In our system analysis for long travels, we give exact details for your specific application.

Selection criteria

Following parameters are required for the design of a trough system:
 ● e-chain® type (Series, width Bi, radius R) ● Travel and travel speed
 ● Fill weight ● Acceleration and/or lagging ● Lateral accelerations ● Environmental conditions

Design and installation of the guide trough

The guide trough is an important element in long travel applications. Usually, the height of the trough must be at least twice that of the e-chain® link height: $H_{Ri} \geq 2 \times ha$. The sides must provide a chamfered opening. The trough inner width is the same as the e-chain® outer width, plus 5 mm ($B_{Ri} = Ba + 4$). Along the side of the trough, where the upper run cannot glide on the lower run, glide bars must be installed. We recommend the use of polymer glide bars from igus®. They are optimally matched to the e-chain® material and achieve the lowest values for friction, noise and wear. Guide troughs with and without glide bars can

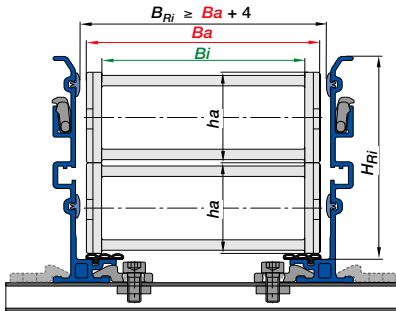

Guide troughs without glide bars - upper run glides on the lower run

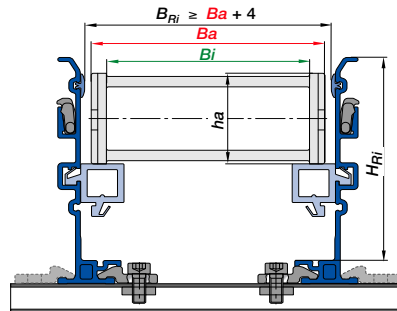

Guide troughs with glide bars - From the middle of the travel the upper run glides off on the glide bar

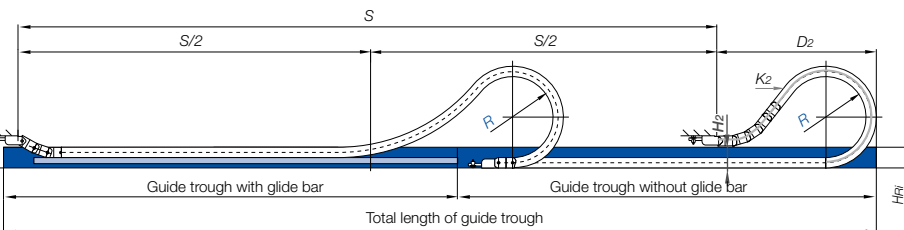

The function of an e-chainsystem® for gliding applications
 The fixed end of the e-chain® is located in the center of the travel distance

S	= Length of travel
R	= Bending radius
H_F	= Required clearance height
K₂	= Further add-on (if the mounting bracket location is set lower)
K	= $\pi \cdot R$ + "safety" Add-on for bending radius (K is taken from the data tables of the individual igus® Series)
D₂	= Over length for long travels gliding
Ba	= Outer e-chain® width
Bi	= Inner e-chain® width
ha	= Outer e-chain® height
H_{Ri}	= Inner trough height
H_{Ra}	= Outer trough height
H₂	= Mounting height (if the mounting bracket location is set lower)
B_{Ri}	= Inner e-chain® width ▶ depending on Ba
B_{Ra}	= Guide trough outer width
L_k	= e-chain® length
L_k = S/2 + K₂ H_{Ri} ≥ 2 x ha B_{Ri} ≥ Ba + 4	
	Guide trough
	Glide bar
	Installation set "Basic"
	C-profile

be obtained for almost all igus® e-chains®. **Important: When assembling the trough parts, the following points must be given particular attention:** ● Properly align all trough parts upon installation ● All screw heads should be flush with the trough ● Smooth levelled transition between the end of the e-chain® and the glide bars ● Solid connection with the glide surface. **These points must be observed when using assembly-friendly igus® guide troughs.**

Selected guide trough Series	Type	Part No. Aluminium SuperTrough	Optional noise dampening	Optional Heavy Duty	Part No. fixed end module ▶ page 9.16
10/B15.015	E2 mini	970.30.SL, 970.31.SL	–	–	970.80
10/B15.025	E2 mini	970.30.SL, 970.31.SL	–	–	970.80
10/B15.038	E2 mini	970.30.SL, 970.31.SL	–	–	970.80
10/B15.050	E2 mini	970.30.SL, 970.31.SL	–	–	970.80
10/B15.5	E2 mini	970.30.SL, 970.31.SL	–	–	970.80
10/B15.6	E2 mini	970.30.SL, 970.31.SL	–	–	970.80
10/B15.7	E2 mini	970.30.SL, 970.31.SL	–	–	970.80
15.015	zipper	970.30.SL, 970.31.SL	–	–	970.80
15.025	zipper	970.30.SL, 970.31.SL	–	–	970.80
15.038	zipper	970.30.SL, 970.31.SL	–	–	970.80
15.050	zipper	970.30.SL, 970.31.SL	–	–	970.80
15.5	zipper	970.30.SL, 970.31.SL	–	–	970.80
15.6	zipper	970.30.SL, 970.31.SL	–	–	970.80
15.7	zipper	970.30.SL, 970.31.SL	–	–	970.80
1500	E2/000	970.30.SL, 970.32.SL	–	–	970.80
2500	E2/000	971.30.SL, 971.31.SL	●	●	971.80
2700	E2/000	972.30.SL, 972.32.SL	●	●	972.81
3500	E2/000	973.30.SL, 973.31.SL	●	●	973.80
250	E2 medium	971.30.SL, 971.31.SL	●	●	–
255	E2 medium	971.30.SL, 971.31.SL	●	●	–
27	E2 medium	972.30.SL, 972.32.SL	●	●	–
350	E2 medium	973.30.SL, 973.31.SL	●	●	–
R48	E2 R	971.30.SL, 971.31.SL	●	●	–
R58	E2 R	972.30.SL, 972.32.SL	●	●	–
R68	E2 R	973.30.SL, 973.31.SL	●	●	–
E4.21 (210)	E4.1	970.30.SL, 970.32.SL	–	–	–
E4.28/R4.28	E4.1	972.02.30.SL, 972.02.31.SL	●	●	972.82
E4.32/H4.32/R4.32	E4.1	972.30.SL, 972.31.SL	●	●	972.80
E4.42/H4.42/R4.42	E4.1	973.30.SL, 973.31.SL	●	●	973.81
E4.56/H4.56/R4.56	E4.1	974.30.SL, 974.31.SL	●	●	974.80
E4.80/H4.80/R4.80	E4.1	975.30.SL, 975.31.SL	●	●	975.80
220/R760	E4/00	972.02.30.SL, 972.02.31.SL	●	●	972.82
280/290/R770	E4/00	972.30.SL, 972.31.SL	●	●	972.80
380/390/R780	E4/00	973.30.SL, 973.31.SL	●	●	973.81
400/410/R880	E4/00	974.30.SL, 974.31.SL	●	●	974.80
2828/2928/R7728	E4/4	972.30.SL, 972.31.SL	●	●	972.80
3838/3938/R7838	E4/4	973.30.SL, 973.31.SL	●	●	973.81
4040/4140/R8840	E4/4	974.30.SL, 974.31.SL	●	●	974.80
4040HD/R8840HD	E4/4	974.30.SL, 974.31.SL	●	●	–
5050/5150/R9850	E4/4	975.30.SL, 975.31.SL	●	●	975.80
5050HD/R9850HD	E4/4	975.30.SL, 975.31.SL	●	●	–
14040/14140/R18840	E4/light	974.30.SL, 974.31.SL	●	●	974.81
14240/14340	E4/light	974.30.SL, 974.31.SL	●	●	974.81
15050/15150/R19850	E4/light	975.30.SL, 975.31.SL	●	●	975.81
15250/15350	E4/light	975.30.SL, 975.31.SL	●	●	975.81
E6.29/R6.29	E6	971.30.SL, 971.31.SL	●	●	–
E6.35	E6	972.02.30.SL, 972.02.31.SL	●	●	972.82
E6.40/R6.40	E6	972.30.SL, 972.31.SL	●	●	972.80
E6.52/R6.52	E6	973.30.SL, 973.31.SL	●	●	973.81
E6.62	E6	974.30.SL, 974.31.SL	●	●	974.80
E6.80	E6	975.30.SL, 975.31.SL	●	●	975.80

● as option possible – not possible

A quick fix for mounting the stationary end of an e-chain*

With this module for the fixed end, fast and easy mounting onto the Aluminum "SuperTrough" is now possible without any drilling. Fast mounting of the e-chain* by clamping onto the aluminum trough ● Quick relocation of the stationary end ● No drilling necessary

Selected guide trough Series	Type	Part No. Steel guide troughs	Part No. Tubular troughs	Part No. Snap-in troughs	Availability Support tray
10/B15.015	E2 mini	91.10, 91.11**	-	91.930	-
10/B15.025	E2 mini	91.20, 91.21**	-	91.930	-
10/B15.038	E2 mini	91.30, 91.31**	-	91.930	-
10/B15.050	E2 mini	91.40, 91.41**	-	91.930	-
10/B15.5	E2 mini	91.50, 91.51**	-	91.930	-
10/B15.6	E2 mini	91.50, 91.51**	-	91.930	-
10/B15.7	E2 mini	91.50, 91.51**	-	91.930	-
15.015	zipper	91.10, 91.11**	-	91.930	-
15.025	zipper	91.20, 91.21**	-	91.930	-
15.038	zipper	91.30, 91.31**	-	91.930	-
15.050	zipper	91.40, 91.41**	-	91.930	-
15.5	zipper	91.50, 91.51**	-	91.930	-
15.6	zipper	91.50, 91.51**	-	91.930	-
15.7	zipper	91.50, 91.51**	-	91.930	-
1500	E2/000	-	92.70, 92.71	92.930	●
2500	E2/000	92.30, 92.31*	92.70, 92.71	92.930	●
2700	E2/000	95.30, 95.31*	95.70, 95.71	95.930	●
3500	E2/000	93.30, 93.31*	93.70, 93.71	93.930	●
250	E2 medium	92.30, 92.31*	92.70, 92.71	92.930	●
255	E2 medium	92.30, 92.31*	92.70, 92.71	-	●
27	E2 medium	95.30, 95.31*	95.70, 95.71	95.930	●
350	E2 medium	93.30, 93.31*	93.70, 93.71	93.930	●
R58	E2 R	95.30, 95.31*	-	-	-
R68	E2 R	93.30, 93.31*	-	-	-
System RX	RX	-	-	-	●
E4.21 (210)	E4.1	-	-	-	●
E4.28/R4.28	E4.1	99.30, 99.31*	-	-	●
E4.32/H4.32/R4.32	E4.1	97.30, 97.31*	-	-	●
E4.42/H4.42/R4.42	E4.1	93.30, 93.31*	-	-	●
E4.56/H4.56/R4.56	E4.1	94.30, 94.31*	-	-	●
E4.80/H4.80/R4.80	E4.1	96.30, 96.31*	-	-	●
1640/1608	E4.1	98.30, 98.31*	-	-	●
800/840	E4.1	90.30, 90.31*	-	-	-
220/R760	E4/00	99.30, 99.31*	-	-	●
280/290/R770	E4/00	97.30, 97.31*	-	-	●
380/390/R780	E4/00	93.30, 93.31*	-	-	●
400/410/R880	E4/00	94.30, 94.31*	-	-	●
600/601/R608	E4/00	98.30, 98.31*	-	-	-
640	E4/00	98.30, 98.31*	-	-	-
2828/2928/R7728	E4/4	97.30, 97.31*	-	-	●
3838/3938/R7838	E4/4	93.30, 93.31*	-	-	●
4040/4140/R8840	E4/4	94.30, 94.31*	-	-	●
4040HD/R8840HD	E4/4	94.30, 94.31*	-	-	-
5050/5150/R9850	E4/4	96.30, 96.31*	-	-	●
5050HD/R9850HD	E4/4	96.30, 96.31*	-	-	-
14040/14140/R18840	E4/light	94.30, 94.31*	-	-	●
14240/14340	E4/light	94.30, 94.31*	-	-	●
15050/15150/R19850	E4/light	96.30, 96.31*	-	-	●
15250/15350	E4/light	96.30, 96.31*	-	-	●
E6.29/R6.29	E6	92.30, 92.31*	92.70, 92.71	92.930	●
E6.35	E6	99.30, 99.31*	-	-	●
E6.40/R6.40	E6	97.30, 97.31*	-	-	●
E6.52/R6.52	E6	93.30, 93.31*	93.70, 93.71	93.930	●
E6.62	E6	94.30, 94.31*	-	-	●
E6.80	E6	96.30, 96.31*	-	-	●

● Available *Stainless steel on request **Steel guide troughs, one-piece

A detailed cross-sectional view of a window frame assembly. The central element is a dark, vertical profile, likely a thermal break or insulation strip. This is flanked by complex aluminum extrusions. On the right side, there are two distinct aluminum blocks, one above and one below the main profile, each secured with a silver-colored bolt. The assembly is shown against a solid blue background. The text 'Alu Super Trough' is overlaid in white, with 'Alu Super' on the left and 'Trough' on the right.

Alu Super Trough

Standard Aluminium "SuperTrough" -
The igus® standard guide trough

- Modular design in two versions - Basic and Heavy Duty
- Very simple, modular assembly
- Side-mounted glide strips for wear protection in high-speed
- Corrosion resistant, seawater resistant aluminium profile
- Flexible assembly - Fastening on substructure independent of profile lengths and butt joints
- Interface connector - Plastic with snap-in connection
- Plastic glide bar made of PE
- Bottom clamp can be mounted -inside or outside- directly on the bottom or on the c-profile
- Glide strips and silencer profile for the minimization of the noise level
- Heavy duty brackets for safe connection also for rough applications
- C-profile for the fixation of the bottom clamp or Heavy duty brackets
- Fixed end module for fast and easy mounting onto the Aluminium "SuperTrough" - without any drilling

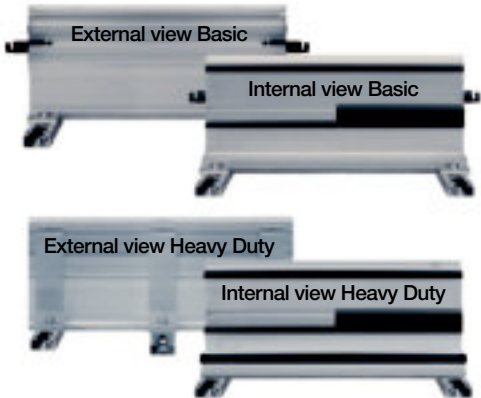

Aluminium "SuperTrough" is available in low cost "basic versions" and can be upgraded for heavy duty applications

Aluminium "SuperTrough" - Overview of sizes

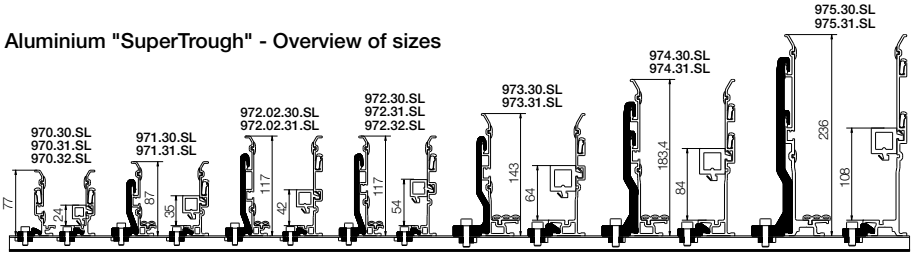

Super-Alu trough configuration according to your requirements

Assemble the right trough suited for your application quickly and easily

- Selection of the suitable guide trough according to the e-chain® Series and e-chain® width *Bi* ► **page 9.10**
- Determine the feeding point of the cables ► **page 9.9**
- Determine travel distance and thus the length of the required guide trough and the number of trough pieces. (Standard length of a trough side plate: 2000 mm). The length of the guide trough - for axial feeding - is calculated from half the travel length **with** and half the travel length **without** the glide bar
- Option: "Sound dampening" with silencer profile ► **page 9.15**
- Number and selection of the assembly kit ► **page 9.14/9.15:**

There are two assembly kit options: Basic (standard), Heavy Duty (for plant construction)

The quantity of the assembly kit is calculated from the number of the trough pieces + 1 kit:

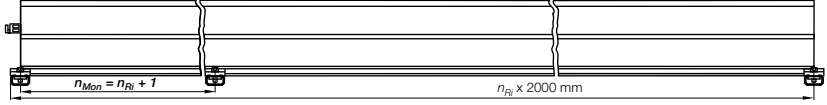

- Selection of the fastening of the assembly kit on the subsurface - igus® C rails option
- If you have opted for an e-chain® with KMA mounting brackets, we offer you a fixed-end module for the quick and simple fastening of the e-chain® in the trough without holes ► **page 9.16**

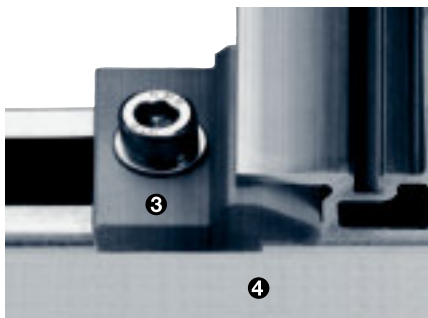
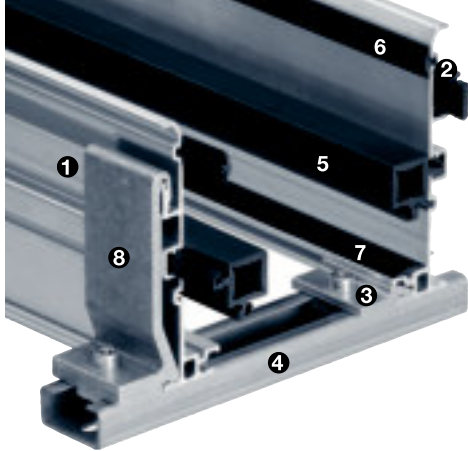

Aluminium "SuperTrough" | Advantages

Aluminum "Super Trough"- the igus® standard

The Aluminum "SuperTrough" is a modular guide trough system for long travels (when e-chains" glide on themselves). Aluminum "SuperTrough" is available in low cost "basic versions" and can be upgraded for heavy duty applications. **This modular usage makes it the igus® recommended standard trough system.**

Huge program

- ① **Aluminium profile** (Standard: 2 m section)
 - Fitted to the igus® e-chain® program
 - For almost all igus® e-chains" available
 - Seawater resistant and corrosion resistant

Fast connection

- ② **Interface connector "Basic"**
 - Snap-on polymer connector
 - Easy assembly, no tools needed
 - Simply clipped on firmly in the provided slot

Simple fastening

- ③ **Bottom clamp "Basic"**
 - Fast and easy single-bolt assembly
 - Slider attached inwards or outwards, directly to the ground or onto a C-profile
 - Standard assembly kit for igus® Super-Alu troughs
 - Ideal for general mechanical engineering
- ④ **C-profile**
 - Hold Bottom clamps or heavy duty brackets
 - Available in zinc-plated or stainless steel

Misalignment-free installation

- Screwing or welding of the profiles not required
- Manifold fastening potentials with bracket, clamping shoe and connectors
- Flexible fastening on substructure independent of profile lengths and butt joints
- No screw heads sticking out inwards
- Even change-over between e-chain® connection and glide bar

Wear-reducing

⑤ Polymer glide bar

- Easy click-on assembly (tongue and groove), no tools needed
- Even support due to the special slot design
- Glide bars are ideally suited for the e-chain® material
- Minimum coefficients in terms of friction noise and wear

⑥ Glide strip

- Protect from wear on the sides
- Easy click-on assembly (tongue and groove), no tools needed



Noise-reducing

⑦ Silencer profile (add-on item)

- Rubber profile insert for additional noise reduction
- Excellent wear and sound values when applied with igus® e-chain® systems: In combination with optimized igus® roller e-chain® and "dampening profile" of the Super-Alu trough, a distinct reduction in noise reduction of 9.0 dB (A) is evident
- Can be optionally ordered



Heavy stress

⑧ Heavy duty bracket (add-on item)

- Safe grip for heavy duty operation
- Easy tongue and groove assembly
- Attached directly to ground or to C-profiles
- Can be optionally ordered

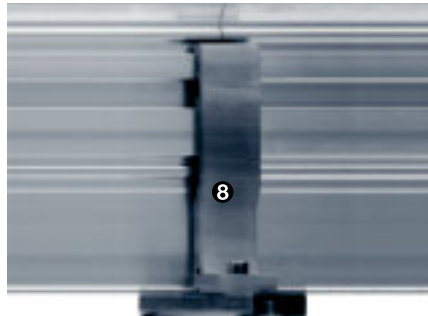

Simple connection to the e-chain®

⑨ Fixed end module

- Quick assistance while fastening of the e-chain® fixed end on the Super-Alu trough
- Fixed end module for fast and easy mounting onto the Aluminium "SuperTrough" - without any drilling
- Can be optionally ordered - Recommended for e-chain® with KMA mounting bracket in conjunction with igus® Super-Alu trough

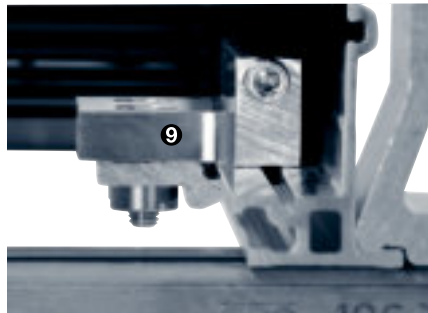

Aluminium "Super Trough"

Phone +49- (0) 22 03-96 49-800
Fax +49- (0) 22 03-96 49-222

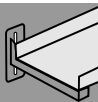

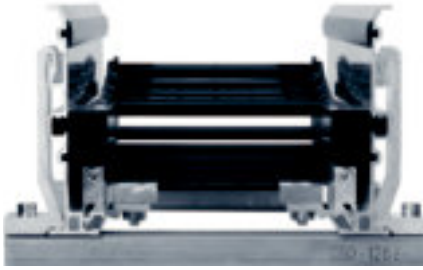

A quick fix for mounting the stationary end of an e-chain®

With this module for the fixed end, fast and easy mounting onto the Alu "SuperTrough" is now possible without any drilling. Fast mounting of the e-chain by clamping onto the alu trough ● Quick relocation of the stationary end ● No drilling necessary

Installation - A) Fixed-end module, B) KMA mounting bracket

- ① Removing the preassembled metal bushings
- ② Use of threaded bushings
- ③ Installation fixed-end module
- ④ Mounting on Super-Alu trough

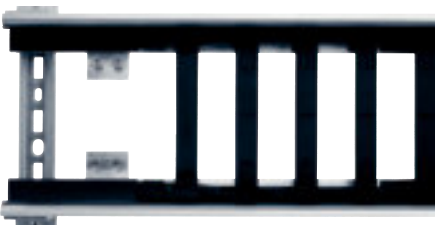
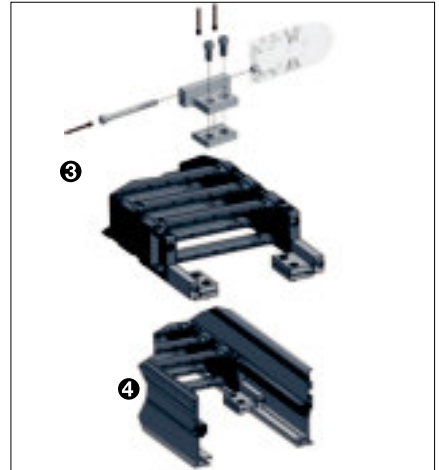
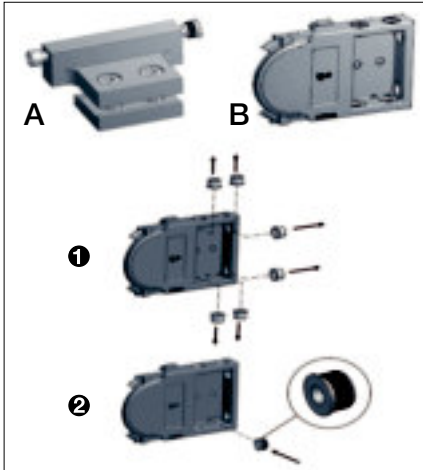

Fixed-end module - Simple fastening of the e-chain* without drilling

Part No.	For Aluminum-SuperTrough	For Series	Application including Inner width (B)	Mounting Bracket
970.80	970.30.SL / 970.31.SL	10, B15, 15/R15, 1500	.025	one-piece
971.80	971.30.SL / 971.31.SL	2500	.07	KMA
972.82	972.02.30.SL / 972.02.31.SL	E4.28/R4.28, 220/R760, E6.35	.06	KMA
972.81	972.30.SL / 972.32.SL	2700	.06	KMA
972.80	972.30.SL / 972.31.SL	E4.32/H4.32/R4.32, 280/290/R770, 2828/2928/R7728, E6.40/R6.40	.06	KMA
973.81	973.30.SL / 973.31.SL	E4.42/H4.42/R4.42, 380/390/R780, 3838/3938/R7838, E6.52/R6.52	.10	KMA
973.80	973.30.SL / 973.31.SL	3500	.100	KMA
974.81	974.30.SL / 974.31.SL	14040/14140/R18840, 14240/14340	.10	KMA
974.80	974.30.SL / 974.31.SL	E4.56/H4.56/R4.56, 400/410/R880, 4040/4140/R8840, E6.62	.10	KMA
975.80	975.30.SL / 975.31.SL	E4.80/H4.80/R4.80, 5050/5150/R9850, E6.80	.10	KMA
975.81	975.30.SL / 975.31.SL	15050/15150/R19850, 15250/15350, 14550/14650/19050	.10	KMA

Material assembly kits: Aluminum AlMg3, seawater resistant. Material screw kits: Standard steel, galvanized. Also available in stainless steel 1.4571 as an option: e.g. 974.80.E4



The igus® Super-Alu trough has been used in test setups since 2005.

Test setup "Axis 1": Speed 1.5 m/s, Travel: 18 m, Mileage so far: about 50,000 km (test runs since 2005)



Test - Glide strips minimize wear after 1.653.187 cycles, 4.300 km

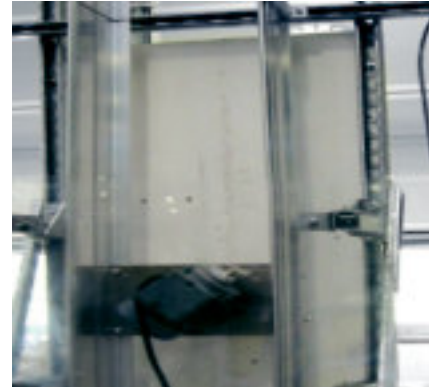

Vibration test: No shifting of trough sections after 108.000.000 rotations at 658 rpm.

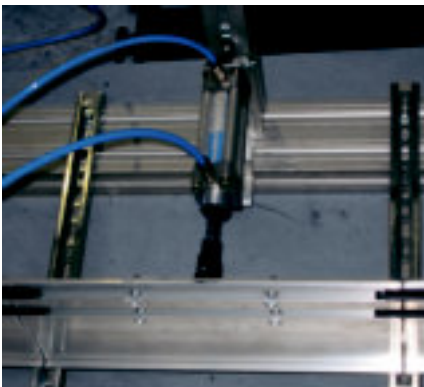

Test - Interface connector

- Push/pull force of 350N
- 9.890.000 cycles without shifting of the connector

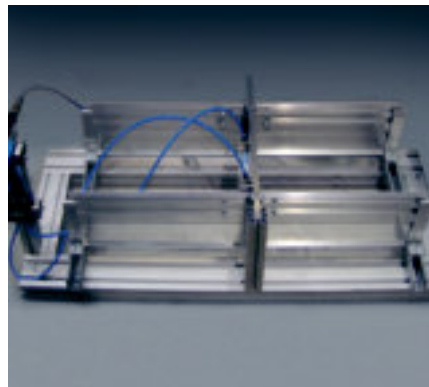

Alternating push- and pull force of 400N is induced on 2 trough side parts, with no deformation after 1.700.000 cycles

Phone +49- (0) 22 03-96 49-800
Fax +49- (0) 22 03-96 49-222

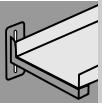

Installation sets | Basic and Heavy Duty



Installation set Basic



Installation set Heavy Duty

Pre-assembly of installation set | Basic - The Standard!



Pre-assemble the clamping shoe and the screw kit



Clip in polymer connector on both sides of the designated support



Fasten Basic assembly set Basic inside ③a or outside ③b (Check stability of the fixing). Please note: half the length of the assembly set and connector must protrude out of the trough. The glide nut should be well fastened in the C-profile

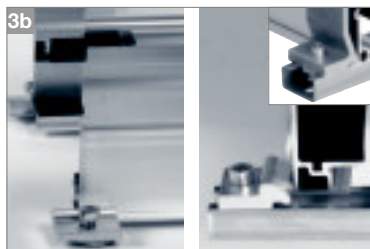

Pre-assembly of installation set | Heavy Duty (alternative)



① Pre-assemble heavy duty bracket and screw set ② Fasten Heavy Duty assembly set outside. Please note: half the length of the assembly set and connector must protrude out of the trough



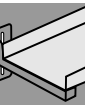

Assembly | Adding the rubber profile (optional)



Cut the rubber profile in accordance to the length of the trough (standard 2 m) and press it into the designated groove. (Pictured: Left and right sides are the same. To be repeated for each trough section.)

Connecting | Trough sections



- ① Join the sides of the trough side parts by pushing them together (min. +2 mm gap!)
- ② + ③ The pre-assembled parts join each trough section centrally

Adjusting the tolerance | Aligning trough sections



- ① Adjust by the necessary minimum "e-chain"/trough" tolerance of 2 mm on both sides. Please note: the inner width B_{Pi} of the trough decreases 2 mm per side with the assembled glide strip (pictured)
- ② Test to ensure the e-chain runs problem free and with low friction in the channel
- ③ After adjusting the minimum tolerance and alignment of all trough sections, please pull tight all screw tight all trough connections. Pay attention thereby to the correct installation direction of the sliding nut (see detail) Starting torque of the assembly set's fixing bolts: M6: 10 Nm / M8: 23 Nm.

Tools for the assembling of the SuperTrough

- Pictogram aid: Hand
- Pictogram aid: Rubber hammer
- Pictogram aid: Hexagonal wrench
- Pictogram aid: Ruler

- ⚠ Please consider health & safety regulations while handling sheet metals. We recommend using protective
- Category II gloves to protect against cuts when handling the aluminium profiles.



For the following
igus® Series

System E2

- 10
- B15
- zipper
- 15/R15

B_a = Outer e-chain* width
 B_i = Inner e-chain* width
 h_a = e-chain* outer height
 H_{Ri} = Inner trough height
 H_{Ra} = Outer trough height
 B_{Ri} = Inner trough width
 B_{Ra} = Outer trough width

$H_{Ri} \geq 2 \cdot h_a$
 $B_{Ri} \geq B_a + 4$

- = Guide trough
- = Glide bar
- = Installation set "Basic"
- = C-profile

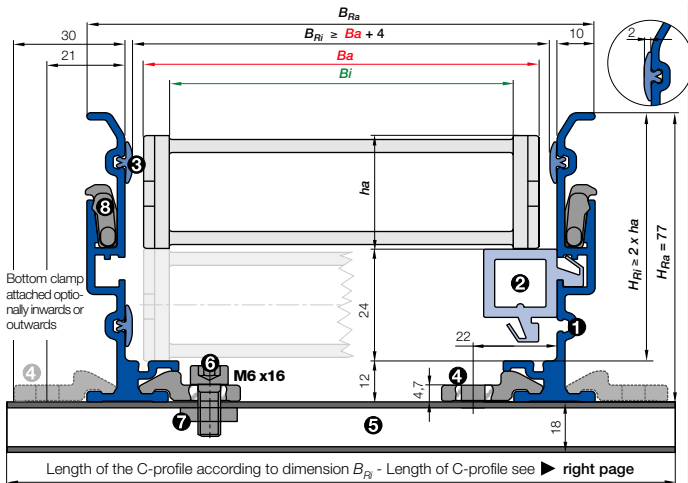

- Components, trough "Basic": ① Trough side parts, aluminum, 2 m ② Glide bar, plastic, 2 m ③ Glide strips, plastic, 2 m (without glide strips on request)
- Components, installation set "Basic": ④ Bottom clamp, aluminum ⑤ C-profile, steel galvanized ⑥ Screw M6 x 16 ⑦ Sliding nut M6 ⑧ Interface connector, plastic

Basic version: Aluminum "SuperTrough" components

Complete guide trough sets - description	Part No.	Weight	kg
① Set of 2 trough side parts, incl. glide strips, without glide bars, 2 m section	970.30.SL	= 4,20 kg	
① Set of 2 trough side parts, incl. glide strips, with glide bars, 2 m section	970.31.SL	= 4,90 kg	
1 Installation set "Basic" without C-profile	960.30	= 0,06 kg	
1 Installation set "Basic" with C-profile	960.30		
Single parts - description			
③ 1 Glide strip, individual, 2 m section	75.01	= 0,06 kg	
④ 1 Bottom clamp, individual	75.40	= 0,03 kg	
⑧ 1 Interface connector, individual	75.60		
⑥ 1 Screw M6 x 16, individual	MAT 0040209		
⑦ 1 Sliding nut M6, individual	MAT 0040057		
② 1 Glide bar, individual, 2 m section	82.79	= 0,42 kg	
⑤ 1 C-profile, individual	92.52	= 0,90 kg/m	

Supplement Part No. with the indicated C-profile-length-index.

Example: 960.30.125

C-profile length-index for your chosen trough inner width B_{Ri} ► see table on the right or the respective page for chosen series

Fixed end module - A quick fix for mounting the stationary end of an e-chain* ► page 9.16



Order example: Length of travel 30 m -
Center mounted for Series 10.5.038.0 with $B_{Ri} = 80$

Guide trough set (set of 2 trough side parts, incl. glide strips) without glide bar	
Order text: 16 m guide trough without glide bar (8 x 2 m sections)	Part No. 970.30.SL
Guide trough set (set of 2 trough side parts, incl. glide strips) with glide bar	
Order text: 16 m guide trough with glide bar (8 x 2 m sections)	Part No. 970.31.SL
Installation set "Basic" complete (guide trough-sets + 1)	
Order text: 17 installation sets "Basic"	Part No. 960.30.125
Module for the fixed end	
Order text: 1 set	Part No. 970.80
Option: For an additional noise dampening with silencer profile, please add Index A Example:	Part No. 970.30.SLA

Lengths of C-profile for Basic version - Bottom clamp attached optionally **inwards** or **outwards**

10				B15				15				R15			
10.5.038.0				B15.5.038.0				15.5.038.0				R15.025.100.0			
B_{Rl} [mm]	Part No. attached inwards	Part No. attached outwards		B_{Rl} [mm]	Part No. attached inwards	Part No. attached outwards		B_{Rl} [mm]	Part No. attached inwards	Part No. attached outwards		B_{Rl} [mm]	Part No. attached inwards	Part No. attached outwards	
.015	30	*	960.30.125	.015	30	*	960.30.125	.015	30	*	960.30.125	.025	40	*	960.30.150
.025	40	*	960.30.150	.025	40	*	960.30.150	.025	40	*	960.30.150	.038	80	*	960.30.150
.038	53	*	960.30.150	.038	53	*	960.30.150	.038	53	*	960.30.150	.063	80	*	960.30.175
.050	65	960.30.125	960.30.175	.050	65	960.30.125	960.30.175	.050	65	960.30.125	960.30.175	.080	98	960.30.150	960.30.200
.5	80	960.30.125	960.30.175	.5	80	960.30.125	960.30.175	.5	80	960.30.125	960.30.175				
.6	98	960.30.150	960.30.200	.6	98	960.30.150	960.30.200	.6	98	960.30.150	960.30.200				
.7	117	960.30.175	960.30.225	.7	117	960.30.175	960.30.225	.7	117	960.30.175	960.30.225				

*upon request

! The inner width of the guide through and the length of the C-Profile of the assembly kit can differ according to the bracket you choose. Please call us!

For the following
igus® Series

System E2

- 1500

System E4

- E4.21 (210)

B_a = Outer e-chain* width
 B_i = Inner e-chain* width
 h_a = e-chain* outer height
 H_{Ri} = Inner trough height
 H_{Ra} = Outer trough height
 B_{Ri} = Inner trough width ►
 depends on dim. B_a
 B_{Ra} = Outer trough width

$H_{Ri} \geq 2 \cdot h_a$
 $B_{Ri} \geq B_a + 4$

● = Guide trough

● = Glide bar

● = Installation set "Basic"

● = C-profile

Calculation - travel
center mounted

Half travel length, rounded down to full 2 m sections = X m guide trough length without glide bars + X m guide trough length with glide bars + installation sets "Basic" (number of trough pieces + 1)

Supplement Part No. with the indicated C-profile-length-index.

Example: 960.30.125

C-profile length-index for your chosen trough inner width B_{Ri} ► see table on the right or the respective page for chosen series

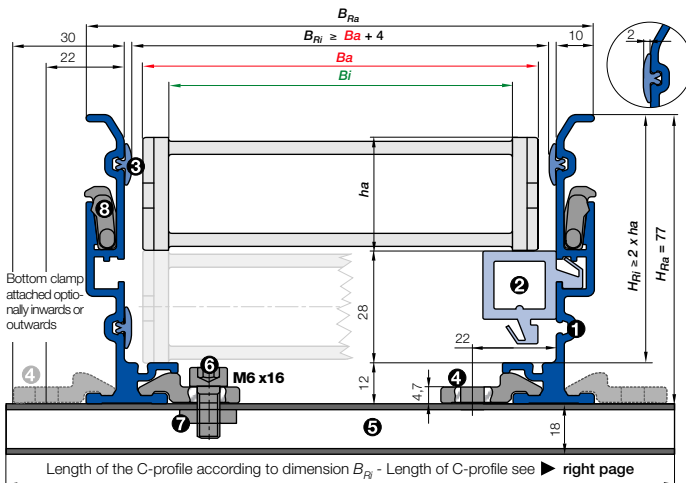

- Components, trough "Basic": ① Trough side parts, aluminum, 2 m ② Glide bar, plastic, 2 m ③ Glide strips, plastic, 2 m (without glide strips on request) ● Components, installation set "Basic": ④ Bottom clamp, aluminum ⑤ C-profile, steel galvanized ⑥ Screw M6 x 16 ⑦ Sliding nut M6 ⑧ Interface connector, plastic

Basic version: Aluminum "SuperTrough" components

Complete guide trough sets - description	Part No.	Weight	kg
① Set of 2 trough side parts, incl. glide strips, without glide bars, 2 m section	970.30.SL	= 4,20 kg	
① Set of 2 trough side parts, incl. glide strips, with glide bars, 2 m section	970.32.SL	= 5,00 kg	
1 Installation set "Basic" without C-profile	960.30	= 0,06 kg	
1 Installation set "Basic" with C-profile	960.30.		
Single parts - description			
③ 1 Glide strip, individual, 2 m section	75.01	= 0,06 kg	
④ 1 Bottom clamp, individual	75.40	= 0,03 kg	
③ 1 Interface connector, individual	75.60		
⑥ 1 Screw M6 x 16, individual	MAT 0040209		
⑦ 1 Sliding nut M6, individual	MAT 0040057		
② 1 Glide bar, individual, 2 m section	82.79	= 0,42 kg	
⑤ 1 C-profile, individual	92.52.	= 0,90 kg/m	

Order example: Length of travel 30 m -
Center mounted for Series E4.21.050.100.0 with $B_{Ri} = 68$

Guide trough set (set of 2 trough side parts, incl. glide strips) without glide bar		
Order text: 16 m guide trough without glide bar (8 x 2 m sections)	Part No.	970.30.SL
Guide trough set (set of 2 trough side parts, incl. glide strips) with glide bar		
Order text: 16 m guide trough with glide bar (8 x 2 m sections)	Part No.	970.32.SL
Installation set "Basic" complete (guide trough-sets + 1)		
Order text: 17 installation sets "Basic"	Part No.	960.30.125
Option: For an additional noise dampening with silencer profile, please add Index A Example:	Part No.	970.30.SLA

Lengths of C-profile for Basic version - Bottom clamp attached optionally **inwards** or **outwards**

1500

1500.050.035.0

E4.21 (210)

E4.21.080.100.0

B_{Rl} [mm]	Part No. attached inwards	Part No. attached outwards	B_{Rl} [mm]	Part No. attached inwards	Part No. attached outwards		
.015	33	*	960.30.125	.030	48	*	960.30.150
.020	38	*	960.30.125	.040	58	960.30.125	960.30.150
.025	43	*	960.30.150	.050	68	960.30.125	960.30.175
.038	56	*	960.30.150	.060	78	960.30.125	960.30.175
.050	68	960.30.125	960.30.175	.070	88	960.30.150	960.30.175
.068	86	960.30.150	960.30.175	.080	98	960.30.150	960.30.200
.080	98	960.30.150	960.30.200	.100	118	960.30.175	960.30.225
.100	118	960.30.175	960.30.225	.120	138	960.30.200	960.30.225
.125	143	960.30.200	960.30.250				

*upon request



For the following
igus® Series

System E2

- 2500
- 255
- System E2 e-tubes
- R48

System E6

- E6.29/R6.29
- E2 medium classic**
- 250 classic

B_a = Outer e-chain* width
 B_i = Inner e-chain* width
 h_a = e-chain* outer height
 H_{Ri} = Inner trough height
 H_{Ra} = Outer trough height
 B_{Ri} = Inner trough width
 B_{Ra} = Outer trough width
 depends on dim. B_a

! $H_{Ri} \geq 2 \cdot h_a$
 ■ $B_{Ri} \geq B_a + 4$

- = Guide trough
- = Glide bar
- = Installation set "Basic"
- = C-profile

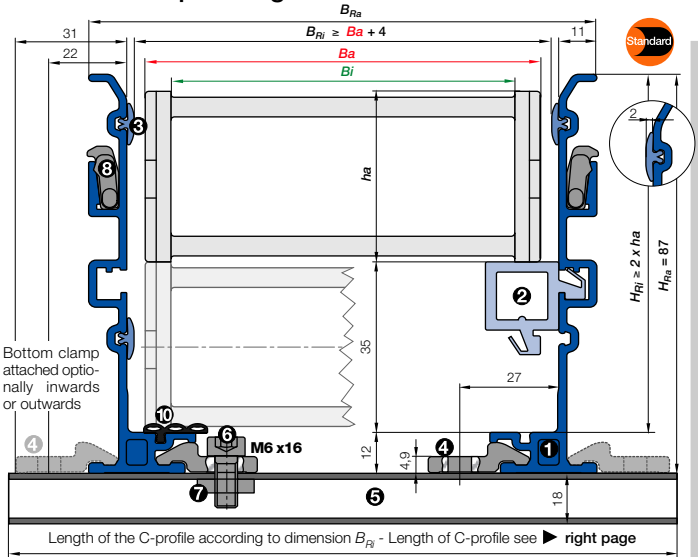

- **Components, trough "Basic":** ① Trough side parts, aluminum, 2 m ② Glide bar, plastic, 2 m ③ Glide strips, plastic, 2 m (without glide strips on request) ⑩ Optional: Silencer profile, rubber
- **Components, installation set "Basic":** ④ Bottom clamp, aluminum ⑤ C-profile, steel galvanized ⑥ Screw M6 x16 ⑦ Sliding nut M6 ⑧ Interface connector, plastic

Basic version: Aluminum "SuperTrough" components

Complete guide trough sets - description	Part No.	Weight	kg
① Set of 2 trough side parts, incl. glide strips, without glide bars, 2 m section	971.30.SL	= 5,00 kg	
① Set of 2 trough side parts, incl. glide strips, with glide bars, 2 m section	971.31.SL	= 6,40 kg	
1 Installation set "Basic" without C-profile	960.30	= 0,06 kg	
1 Installation set "Basic" with C-profile	960.30.		
Single parts - description			
② 1 Glide strip, individual, 2 m section	75.01	= 0,06 kg	
⑩ 1 Silencer profile, rubber, individual, 2 m section	75.67.H		
④ 1 Bottom clamp, individual	75.40	= 0,03 kg	
⑧ 1 Interface connector, individual	75.60		
⑥ 1 Screw M6 x 16, individual	MAT 0040209		
⑦ 1 Sliding nut M6, individual	MAT 0040057		
② 1 Glide bar, individual, 2 m section	82.79	= 0,60 kg	
⑤ 1 C-profile, individual	92.52.	= 0,90 kg/m	



Calculation - travel center mounted

Half travel length, rounded down to full 2 m sections = X m guide trough length without glide bars + X m guide trough length with glide bars + installation sets "Basic" (number of trough pieces + 1)

Supplement Part No. with the indicated C-profile-length-index.

Example: 960.30. 150

C-profile length-index for your chosen trough inner width B_{Ri} ► see table on the right or the respective page for chosen series



Fixed end module - A quick fix for mounting the stationary end of an e-chain* ► page 9.16



Order example: Length of travel 30 m - Center mounted for Series 2500.07.200.0 with $B_{Ri} = 97$

Guide trough set (set of 2 trough side parts, incl. glide strips) without glide bar	
Order text: 16 m guide trough without glide bar (8 x 2 m sections)	Part No. 971.30.SL
Guide trough set (set of 2 trough side parts, incl. glide strips) with glide bar	
Order text: 16 m guide trough with glide bar (8 x 2 m sections)	Part No. 971.31.SL
Installation set "Basic" complete (guide trough-sets + 1)	
Order text: 17 installation sets "Basic"	Part No. 960.30. 150
Module for the fixed end	
Order text: 1 set	Part No. 971.80
Option: For an additional noise dampening with silencer profile, please add Index A Example:	Part No. 971.30.SLA

Lengths of C-profile for Basic version - Bottom clamp attached optionally **inwards** or **outwards**

2500			255			E6.29/R6.29			R48		
2500.02.200.0			255.03.200.0			E6.29.030.100.0			48.050.100.0		
B_{Ri} [mm]	Part No. attached inwards	Part No. attached outwards	B_{Ri} [mm]	Part No. attached inwards	Part No. attached outwards	B_{Ri} [mm]	Part No. attached inwards	Part No. attached outwards	B_{Ri} [mm]	Part No. attached inwards	Part No. attached outwards
.02	45	*	960.30.150	.03	58	*	960.30.150	.030	50	*	960.30.150
.03	58	*	960.30.150	.05	77	960.30.125	960.30.175	.040	60	*	960.30.175
.05	77	960.30.125	960.30.175	.07	97	960.30.150	960.30.200	.050	70	*	960.30.175
.07	97	960.30.150	960.30.200	.10	123	960.30.175	960.30.225	.060	80	960.30.150	960.30.175
.09	109	960.30.175	960.30.225					.070	90	960.30.150	960.30.200
.10	123	960.30.175	960.30.225					.080	100	960.30.150	960.30.200
.12	145	960.30.200	960.30.250					.090	110	960.30.175	960.30.225
								.100	120	960.30.175	960.30.225
								.110	130	960.30.200	960.30.225
								.120	140	960.30.200	960.30.250

*upon request

"Heavy Duty" Version | Installation set Part No. 971.50

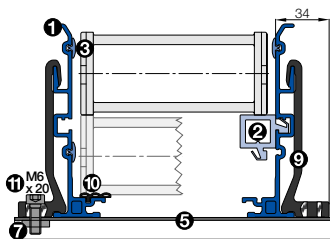

- **Components, trough "Heavy Duty":** ① Trough side parts, aluminum, 2 m ② Glide bar, plastic, 2 m ③ Glide strips, plastic 2 m (without glide strips on request) ⑩ Optional: Silencer profile, rubber
- **Components, installation set "Heavy Duty":** ⑤ C-profile, steel galvanized ⑦ Sliding nut M6 ⑧ Heavy duty bracket, aluminum ⑪ Screw M6 x 20

Note: Dimensions similar to Basic version!
Exception: Heavy duty bracket, see drawing



- = Guide trough
- = Glide bar
- = Installation set "Heavy duty"
- = C-profile

Insert for the installation set "Heavy-Duty": **971.50.XXX** instead of **960.30.XXX** on the right column "attached outwards"

"Heavy Duty" installation set Part No. 971.50.150

! The inner width of the guide through and the length of the C-Profile of the assembly kit can differ according to the bracket you choose. Please call us!

For the following igus® Series

System E4

- E4.28/R4.28

- 220/R760

System E6

- E6.35

B_a = Outer e-chain® width
 B_i = Inner e-chain® width
 h_a = e-chain® outer height
 H_{Ri} = Inner trough height
 H_{Ra} = Outer trough height
 B_{Ri} = Inner trough width
 B_{Ra} = Outer trough width

$H_{Ri} \geq 2 \cdot h_a$
 $B_{Ri} \geq B_a + 4$

- = Guide trough
- = Glide bar
- = Installation set "Basic"
- = C-profile

Calculation - travel center mounted

Half travel length, rounded down to full 2 m sections = X m guide trough length without glide bars + X m guide trough length with glide bars + installation sets "Basic" (number of trough pieces + 1)

Supplement Part No. with the indicated C-profile-length-index.

Example: 960.30.175

C-profile length-index for your chosen trough inner width B_{Ri} ▶ see table on the right or the respective page for chosen series

Fixed end module - A quick fix for mounting the stationary end of an e-chain® ▶ [page 9.16](#)

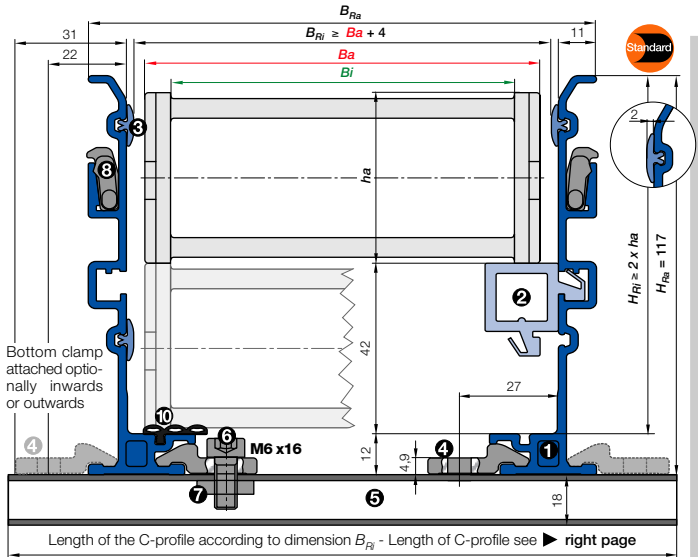

- **Components, trough "Basic":** 1 Trough side parts, aluminum, 2 m 2 Glide bar, plastic, 2 m 3 Glide strips, plastic, 2 m (without glide strips on request) 10 Optional: Silencer profile, rubber
- **Components, installation set "Basic":** 4 Bottom clamp, aluminum 5 C-profile, steel galvanized 6 Screw M6 x16 7 Sliding nut M6 8 Interface connector, plastic

Basic version: Aluminum "SuperTrough" components

Complete guide trough sets - description	Part No.	Weight	kg
1 Set of 2 trough side parts, incl. glide strips, without glide bars, 2 m section	972.02.30.SL	= 6,00 kg	
1 Set of 2 trough side parts, incl. glide strips, with glide bars, 2 m section	972.02.31.SL	= 7,40 kg	
1 Installation set "Basic" without C-profile	960.30	= 0,06 kg	
1 Installation set "Basic" with C-profile	960.30.		
Single parts - description			
8 1 Glide strip, individual, 2 m section	75.01	= 0,06 kg	
10 1 Silencer profile, rubber, individual, 2 m section	75.67.H		
4 1 Bottom clamp, individual	75.40	= 0,03 kg	
8 1 Interface connector, individual	75.60		
6 1 Screw M6 x 16, individual	MAT 0040209		
7 1 Sliding nut M6, individual	MAT 0040057		
2 1 Glide bar, individual, 2 m section	82.79	= 0,60 kg	
5 1 C-profile, individual	92.52.	= 0,90 kg/m	

Order example: Length of travel 30 m - Center mounted for Series E6.35.100.055.0 with $B_{Ri} = 124$

Guide trough set (set of 2 trough side parts, incl. glide strips) without glide bar	Order text: 16 m guide trough without glide bar (8 x 2 m sections)	Part No. 972.02.30.SL
Guide trough set (set of 2 trough side parts, incl. glide strips) with glide bar	Order text: 16 m guide trough with glide bar (8 x 2 m sections)	Part No. 972.02.31.SL
Installation set "Basic" complete (guide trough-sets + 1)	Order text: 17 installation sets "Basic"	Part No. 960.30.175
Module for the fixed end	Order text: 1 set	Part No. 972.82
Option: For an additional noise dampening with silencer profile, please add Index A Example:		Part No. 972.02.30.SLA

Lengths of C-profile for Basic version - Bottom clamp attached optionally **inwards** or **outwards**

E4.28/R4.28			220/R760			E6.35					
E4.28.070.250.0			220.070.250.0			E6.35.100.063.0					
B_{Rl} [mm]	Part No. attached inwards	Part No. attached outwards	B_{Rl} [mm]	Part No. attached inwards	Part No. attached outwards	B_{Rl} [mm]	Part No. attached inwards	Part No. attached outwards			
.040	64	*	960.30.175	.040	64	*	960.30.175	.030	54	*	960.30.150
.050	74	960.30.125	960.30.175	.050	74	960.30.125	960.30.175	.040	64	*	960.30.175
.062	86	960.30.150	960.30.200	.062	86	960.30.150	960.30.200	.050	74	960.30.125	960.30.175
.070	94	960.30.150	960.30.200	.070	94	960.30.150	960.30.200	.060	84	960.30.150	960.30.200
.075	99	960.30.150	960.30.200	.075	99	960.30.150	960.30.200	.070	94	960.30.150	960.30.200
.087	111	960.30.175	960.30.225	.087	111	960.30.175	960.30.225	.080	104	960.30.150	960.30.200
.100	124	960.30.175	960.30.225	.100	124	960.30.175	960.30.225	.090	114	960.30.175	960.30.225
.125	149	960.30.200	960.30.250	.125	149	960.30.200	960.30.250	.100	124	960.30.175	960.30.225
.150	174	960.30.225	960.30.275	.150	174	960.30.225	960.30.275	.110	134	960.30.200	960.30.250
.175	199	960.30.250	960.30.300	.175	199	960.30.250	960.30.300	.120	144	960.30.200	960.30.250
.200	224	960.30.275	960.30.325	.200	224	960.30.275	960.30.325				
.225	249	960.30.300	960.30.350	.225	249	960.30.300	960.30.350				
.250	274	960.30.325	960.30.375	.250	274	960.30.325	960.30.375				
.275	299	960.30.350	960.30.400	.275	299	960.30.350	960.30.400				
.300	324	960.30.375	960.30.425	.300	324	960.30.375	960.30.425				

*upon request

"Heavy Duty" Version | Installation set Part No. 972.50

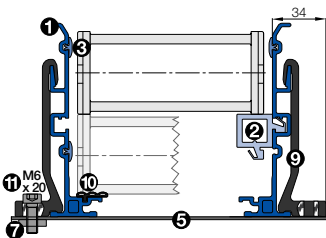

- **Components, trough "Heavy Duty":** ① Trough side parts, aluminum, 2 m ② Glide bar, plastic, 2 m ③ Glide strips, plastic 2 m (without glide strips on request) ⑩ Optional: Silencer profile, rubber
- **Components, installation set "Heavy Duty":** ⑤ C-profile, steel galvanized ⑦ Sliding nut M6 ⑧ Heavy duty bracket, aluminum ⑪ Screw M6 x 20

Note: Dimensions similar to Basic version!
Exception: Heavy duty bracket, see drawing



- = Führungsrinnen-Set
- = Gleitschiene
- = Montageset "Heavy duty"
- = C-Profil

Insert for the installation set "Heavy-Duty": **972.50.XXX** instead of 960.30.XXX on the right column "attached outwards"

"Heavy Duty" installation set Part No. 972.50.150

! The inner width of the guide through and the length of the C-Profile of the assembly kit can differ according to the bracket you choose. Please call us!



For the following
igus® Series

System E4

- E4.32/H4.32/R4.32
- 280/290/R770
- 2828/2928/R7728

System E6

- E6.40/R6.40

B_a = Outer e-chain* width
 B_i = Inner e-chain* width
 h_a = e-chain* outer height
 H_{Ri} = Inner trough height
 H_{Ra} = Outer trough height
 B_{Ri} = Inner trough width
 B_{Ra} = Outer trough width

! $H_{Ri} \geq 2 \cdot h_a$
 ■ $B_{Ri} \geq B_a + 4$

- = Guide trough
- = Glide bar
- = Installation set "Basic"
- = C-profile



Calculation - travel
center mounted

Half travel length, rounded down to full 2 m sections = X m guide trough length without glide bars + X m guide trough length with glide bars + installation sets "Basic" (number of trough pieces + 1)

Supplement Part No. with the indicated C-profile-length-index.

Example: 960.30.150

C-profile length-index for your chosen trough inner width B_{Ri} ► see table on the right or the respective page for chosen series



Fixed end module - A quick fix for mounting the stationary end of an e-chain* ► page 9.16

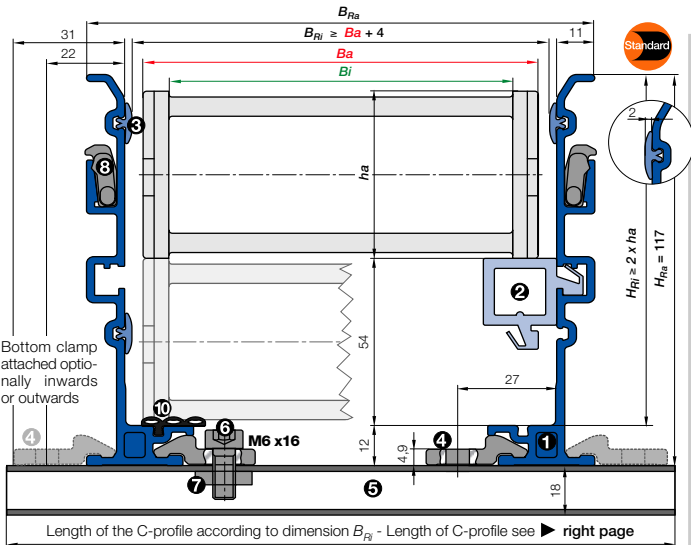

- Components, trough "Basic": 1 Trough side parts, aluminum, 2 m 2 Glide bar, plastic, 2 m 3 Glide strips, plastic, 2 m (without glide strips on request) 10 Optional: Silencer profile, rubber
- Components, installation set "Basic": 4 Bottom clamp, aluminum 5 C-profile, steel galvanized 6 Screw M6 x16 7 Sliding nut M6 8 Interface connector, plastic

Basic version: Aluminum "SuperTrough" components

Complete guide trough sets - description	Part No.	Weight	kg
1 Set of 2 trough side parts, incl. glide strips, without glide bars, 2 m section	972.30.SL	= 6,00 kg	
1 Set of 2 trough side parts, incl. glide strips, with glide bars, 2 m section	972.31.SL	= 7,40 kg	
1 Installation set "Basic" without C-profile	960.30	= 0,06 kg	
1 Installation set "Basic" with C-profile	960.30.		
Single parts - description			
8 1 Glide strip, individual, 2 m section	75.01	= 0,06 kg	
10 1 Silencer profile, rubber, individual, 2 m section	75.67.H		
4 1 Bottom clamp, individual	75.40	= 0,03 kg	
8 1 Interface connector, individual	75.60		
6 1 Screw M6 x 16, individual	MAT 0040209		
7 1 Sliding nut M6, individual	MAT 0040057		
2 1 Glide bar, individual, 2 m section	82.79	= 0,60 kg	
5 1 C-profile, individual	92.52.	= 0,90 kg/m	



Order example: Length of travel 30 m -
Center mounted for Series E4.32.07.200.0 with $B_{Ri} = 102$

Guide trough set (set of 2 trough side parts, incl. glide strips) without glide bar	Order text: 16 m guide trough without glide bar (8 x 2 m sections)	Part No.	972.30.SL
Guide trough set (set of 2 trough side parts, incl. glide strips) with glide bar	Order text: 16 m guide trough with glide bar (8 x 2 m sections)	Part No.	972.31.SL
Installation set "Basic" complete (guide trough-sets + 1)	Order text: 17 installation sets "Basic"	Part No.	960.30.150
Module for the fixed end	Order text: 1 set	Part No.	972.80
Option: For an additional noise dampening with silencer profile, please add Index A Example:		Part No.	972.30.SLA

Lengths of C-profile for Basic version - Bottom clamp attached optionally inwards or outwards

E4.32/H4.32/R4.32				280/290/R770				2828/2928/R7728				E6.40/R6.40			
E4.32.05.200.0				280.05.200.0				2828.05.200.0				E6.40.040.063.0			
B_{Ri} [mm]	Part No. attached inwards	Part No. attached outwards		B_{Ri} [mm]	Part No. attached inwards	Part No. attached outwards		B_{Ri} [mm]	Part No. attached inwards	Part No. attached outwards		B_{Ri} [mm]	Part No. attached inwards	Part No. attached outwards	
.05	77	960.30.125	960.30.175	.05	77	960.30.125	960.30.175	.05	78	960.30.125	960.30.175	.040	64	*	960.30.175
.06	95	960.30.150	960.30.200	.06	95	960.30.150	960.30.200	.06	96	960.30.150	960.30.200	.050	74	960.30.125	960.30.175
.07	102	960.30.150	960.30.200	.07	102	960.30.150	960.30.200	.07	103	960.30.150	960.30.200	.062	86	960.30.150	960.30.200
.087	114	960.30.175	960.30.225	.087	114	960.30.175	960.30.225	.087	115	960.30.175	960.30.225	.070	94	960.30.150	960.30.200
.10	127	960.30.175	960.30.225	.10	127	960.30.175	960.30.225	.10	128	960.30.175	960.30.225	.075	99	960.30.150	960.30.200
.11	135	960.30.200	960.30.250	.11	135	960.30.200	960.30.250	.11	136	960.30.200	960.30.225	.087	111	960.30.175	960.30.225
.112	140	960.30.200	960.30.250	.112	140	960.30.200	960.30.250	.112	141	960.30.200	960.30.250	.100	124	960.30.175	960.30.225
.12	152	960.30.200	960.30.250	.12	152	960.30.200	960.30.250	.12	153	960.30.200	960.30.250	.125	149	960.30.200	960.30.250
.137	165	960.30.225	960.30.275	.137	165	960.30.225	960.30.275	.137	166	960.30.225	960.30.275	.150	174	960.30.225	960.30.275
.15	177	960.30.225	960.30.275	.15	177	960.30.225	960.30.275	.15	178	960.30.225	960.30.275	.175	199	960.30.250	960.30.300
.162	190	960.30.250	960.30.300	.162	190	960.30.250	960.30.300	.162	191	960.30.250	960.30.300	.200	224	960.30.275	960.30.325
.17	195	960.30.250	960.30.300	.17	195	960.30.250	960.30.300	.17	196	960.30.250	960.30.300	.225	249	960.30.300	960.30.350
.18	202	960.30.250	960.30.300	.18	202	960.30.250	960.30.300	.18	203	960.30.250	960.30.300	.250	274	960.30.325	960.30.375
.187	215	960.30.275	960.30.325	.187	215	960.30.275	960.30.325	.187	216	960.30.275	960.30.325	.275	299	960.30.350	960.30.400
.20	227	960.30.275	960.30.325	.20	227	960.30.275	960.30.325	.20	228	960.30.275	960.30.325	.300	324	960.30.375	960.30.425
.212	240	960.30.300	960.30.350	.212	240	960.30.300	960.30.350	.212	241	960.30.300	960.30.350				
.23	252	960.30.300	960.30.350	.23	252	960.30.300	960.30.350	.23	253	960.30.300	960.30.350				
.237	265	960.30.325	960.30.375	.237	265	960.30.325	960.30.375	.237	266	960.30.325	960.30.375				
.25	277	960.30.325	960.30.375	.25	277	960.30.325	960.30.375	.25	278	960.30.325	960.30.375				
.262	290	960.30.350	960.30.400	.262	290	960.30.350	960.30.400	.262	291	960.30.350	960.30.400				
.28	302	960.30.350	960.30.400	.28	302	960.30.350	960.30.400	.28	303	960.30.350	960.30.400				
.29	315	960.30.375	960.30.425	.29	315	960.30.375	960.30.425	.29	316	960.30.375	960.30.425				
.30	327	960.30.375	960.30.425	.30	327	960.30.375	960.30.425	.30	328	960.30.375	960.30.425				
.312	340	960.30.400	960.30.450	.312	340	960.30.400	960.30.450	.312	341	960.30.400	960.30.450				
.325	352	960.30.400	960.30.450	.325	352	960.30.400	960.30.450	.325	353	960.30.400	960.30.450				
.337	365	960.30.425	960.30.475	.337	365	960.30.425	960.30.475	.337	366	960.30.425	960.30.475				
.350	377	960.30.425	960.30.475	.350	377	960.30.425	960.30.475	.350	378	960.30.425	960.30.475				
.362	390	960.30.450	960.30.500	.362	390	960.30.450	960.30.500	.362	391	960.30.450	960.30.500				
.375	402	960.30.450	960.30.500	.375	402	960.30.450	960.30.500	.375	403	960.30.450	960.30.500				
.387	415	960.30.475	960.30.525	.387	415	960.30.475	960.30.525	.387	416	960.30.475	960.30.525				
.400	427	960.30.475	960.30.525	.400	427	960.30.475	960.30.525	.400	428	960.30.475	960.30.525				

*upon request

"Heavy Duty" Version | Installation set Part No. 972.50

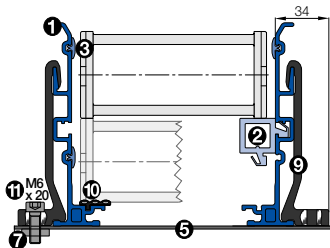

- **Components, trough "Heavy Duty":** ① Trough side parts, aluminum, 2 m ② Glide bar, plastic, 2 m ③ Glide strips, plastic 2 m (without glide strips on request) ⑩ Optional: Silencer profile, rubber
- **Components, installation set "Heavy Duty":** ⑤ C-profile, steel galvanized ⑦ Sliding nut M6 ⑧ Heavy duty bracket, aluminum ⑪ Screw M6 x 20



- = Guide trough
- = Glide bar
- = Installation set "Heavy duty"
- = C-profile

Note: Dimensions similar to Basic version!
Exception: Heavy duty bracket, see drawing

Insert for the installation set "Heavy-Duty": **972.50.XXX** instead of **960.30.XXX** on the right column "attached outwards"

"Heavy Duty" installation set Part No. 972.50.150

! The inner width of the guide through and the length of the C-Profile of the assembly kit can differ according to the bracket you choose. Please call us!

For the following igus® Series

System E2

- 2700

System E2 e-tubes

- R58
- E2 medium classic
- 27 classic

- B_a = Outer e-chain* width
- B_i = Inner e-chain* width
- h_a = e-chain* outer height
- H_{Ri} = Inner trough height
- H_{Ra} = Outer trough height
- B_{Ri} = Inner trough width
- depends on dim. B_a
- B_{Ra} = Outer trough width

$H_{Ri} \geq 2 \cdot h_a$
 $B_{Ri} \geq B_a + 4$

- = Guide trough
- = Glide bar
- = Installation set "Basic"
- = C-profile

Calculation - travel center mounted

Half travel length, rounded down to full 2 m sections = X m guide trough length without glide bars + X m guide trough length with glide bars + installation sets "Basic" (number of trough pieces + 1)

Supplement Part No. with the indicated C-profile-length-index.

Example : 960.30.150

C-profile length-index for your chosen trough inner width B_{Ri} ► see table on the right or the respective page for chosen series

Fixed end module - A quick fix for mounting the stationary end of an e-chain* ► page 9.16

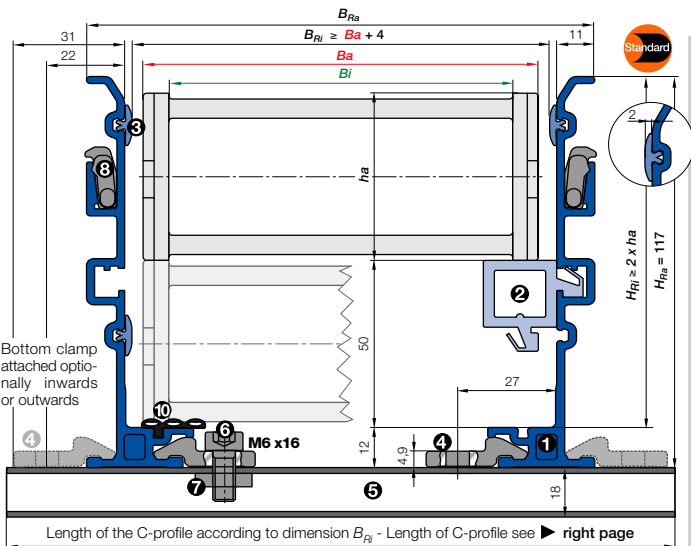

- **Components, trough "Basic":** ① Trough side parts, aluminum, 2 m ② Glide bar, plastic, 2 m ③ Glide strips, plastic, 2 m (without glide strips on request) ⑩ Optional: Silencer profile, rubber
- **Components, installation set "Basic":** ④ Bottom clamp, aluminum ⑤ C-profile, steel galvanized ⑥ Screw M6 x16 ⑦ Sliding nut M6 ⑧ Interface connector, plastic

Basic version: Aluminum "SuperTrough" components

Complete guide trough sets - description	Part No.	Weight	kg
① Set of 2 trough side parts, incl. glide strips, without glide bars, 2 m section	972.30.SL	= 6,00 kg	
① Set of 2 trough side parts, incl. glide strips, with glide bars, 2 m section	972.32.SL	= 7,40 kg	
1 Installation set "Basic" without C-profile	960.30	= 0,06 kg	
1 Installation set "Basic" with C-profile	960.30.		
Single parts - description			
③ 1 Glide strip, individual, 2 m section	75.01	= 0,06 kg	
⑩ 1 Silencer profile, rubber, individual, 2 m section	75.67.H		
④ 1 Bottom clamp, individual	75.40	= 0,03 kg	
⑧ 1 Interface connector, individual	75.60		
⑥ 1 Screw M6 x 16, individual	MAT 0040209		
⑦ 1 Sliding nut M6, individual	MAT 0040057		
② 1 Glide bar, individual, 2 m section	82.79	= 0,60 kg	
⑤ 1 C-profile, individual	92.52.	= 0,90 kg/m	



Order example: Length of travel 30 m - Center mounted for Series 2700.07.200.0 with $B_{Ri} = 95$

Guide trough set (set of 2 trough side parts, incl. glide strips) without glide bar		
Order text: 16 m guide trough without glide bar (8 x 2 m sections)	Part No.	972.30.SL
Guide trough set (set of 2 trough side parts, incl. glide strips) with glide bar		
Order text: 16 m guide trough with glide bar (8 x 2 m sections)	Part No.	972.32.SL
Installation set "Basic" complete (guide trough-sets + 1)		
Order text: 17 installation sets "Basic"	Part No.	960.30.150
Module for the fixed end		
Order text: 1 set	Part No.	972.81
Option: For an additional noise dampening with silencer profile, please add Index A Example:	Part No.	972.30.SLA

Lengths of C-profile for Basic version - Bottom clamp attached optionally **inwards** or **outwards**

2700

2700,05,200.0

B_{Rl} [mm]	Part No. attached inwards	Part No. attached outwards
.05 70	*	960.30.175
.06 85	960.30.150	960.30.200
.07 95	960.30.150	960.30.200
.09 110	960.30.175	960.30.225
.10 120	960.30.175	960.30.225
.12 145	960.30.200	960.30.250
.15 170	960.30.225	960.30.275
.17 198	960.30.250	960.30.300

R58

58,075,200.0

B_{Rl} [mm]	Part No. attached inwards	Part No. attached outwards
.050 70	*	960.30.175
.075 95	960.30.150	960.30.200
.100 120	960.30.175	960.30.225
.125 145	960.30.200	960.30.250
.150 170	960.30.225	960.30.275
.175 195	960.30.250	960.30.300
.200 220	960.30.275	960.30.325

*upon request

"Heavy Duty" Version | Installation set Part No. Nr. 972.50

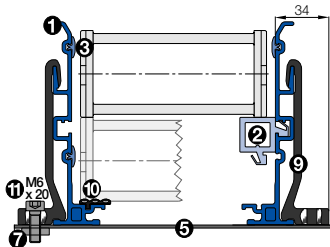

- **Components, trough "Heavy Duty":** ① Trough side parts, aluminum, 2 m ② Glide bar, plastic, 2 m ③ Glide strips, plastic 2 m (without glide strips on request) ⑩ Optional: Silencer profile, rubber
- **Components, installation set "Heavy Duty":** ⑤ C-profile, steel galvanized ⑦ Sliding nut M6 ⑨ Heavy duty bracket, aluminum ⑪ Screw M6 x 20



- = Guide trough
- = Glide bar
- = Installation set "Heavy duty"
- = C-profile

Note: Dimensions similar to Basic version!
Exception: Heavy duty bracket, see drawing



Insert for the installation set "Heavy-Duty": **972.50.XXX** instead of 960.30.XXX on the right column "attached outwards"

"Heavy Duty" installation set Part No. 972.50. 150

! The inner width of the guide through and the length of the C-Profile of the assembly kit can differ according to the bracket you choose. Please call us!



For the following
igus® Series

System E2

- 3500

System E2 e-tubes

- R68

System E4

- E4.42/H4.42/R4.42
- 380/390/R780
- 3838/3938/R7838

System E6

- E6.52/R6.52

E2 medium classic

- 350 classic

B_a = Outer e-chain* width
 B_i = Inner e-chain* width
 h_a = e-chain* outer height
 H_{Ri} = Inner trough height
 H_{Ra} = Outer trough height
 B_{Ri} = Inner trough width ▶ depends on dim. B_a
 B_{Ra} = Outer trough width

! $H_{Ri} \geq 2 \cdot h_a$
 $B_{Ri} \geq B_a + 4$

- = Guide trough
- = Glide bar
- = Installation set "Basic"
- = C-profile



Calculation - travel center mounted

Half travel length, rounded down to full 2 m sections = X m guide trough length without glide bars + X m guide trough length with glide bars + installation sets "Basic" (number of trough pieces + 1)

Supplement Part No. with the indicated C-profile-length-index.

Example: 960.40.175

C-profile length-index for your chosen trough inner width B_{Ri} ▶ see table on the right or the respective page for chosen series



Fixed end module - A quick fix for mounting the stationary end of an e-chain* ▶ page 9.16

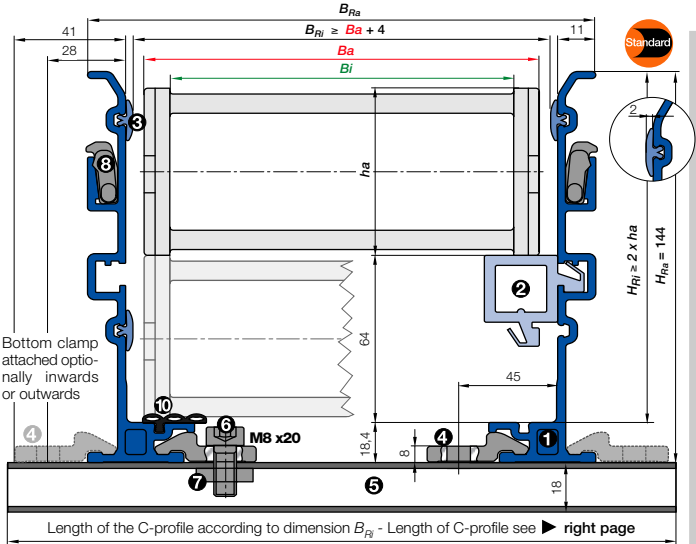

- **Components, trough "Basic":** ① Trough side parts, aluminum, 2 m ② Glide bar, plastic, 2 m ③ Glide strips, plastic, 2 m (without glide strips on request) ⑩ Optional: Silencer profile, rubber
- **Components, installation set "Basic":** ④ Bottom clamp, aluminum ⑤ C-profile, steel galvanized ⑥ Screw M8 x 20 ⑦ Sliding nut M8 ⑧ Interface connector, plastic

Basic version: Aluminum "SuperTrough" components

Complete guide trough sets - description	Part No.	Weight	kg
① Set of 2 trough side parts, incl. glide strips, without glide bars, 2 m section	973.30.SL	= 8,00 kg	
① Set of 2 trough side parts, incl. glide strips, with glide bars, 2 m section	973.31.SL	= 10,8 kg	
1 Installation set "Basic" without C-profile	960.40.	= 0,08 kg	
1 Installation set "Basic" with C-profile	960.40.		
Single parts - description			
② 1 Glide strip, individual, 2 m section	75.01	= 0,06 kg	
⑩ 1 Silencer profile, rubber, individual, 2 m section	75.68.H		
④ 1 Bottom clamp, individual	75.50	= 0,04 kg	
③ 1 Interface connector, individual	75.60		
⑥ 1 Screw M8 x 20, individual	MAT 0040445		
⑦ 1 Sliding nut M8, individual	MAT 0040413		
② 1 Glide bar, individual, 2 m section	83.79	= 1,30 kg	
⑤ 1 C-profile, individual	92.52.	= 0,90 kg/m	



Order example: Length of travel 30 m - Center mounted for Series 3500.100.200.0 with $B_{Ri} = 124$

Guide trough set (set of 2 trough side parts, incl. glide strips) without glide bar	Order text: 16 m guide trough without glide bar (8 x 2 m sections)	Part No.	973.30.SL
Guide trough set (set of 2 trough side parts, incl. glide strips) with glide bar	Order text: 16 m guide trough with glide bar (8 x 2 m sections)	Part No.	973.31.SL
Installation set "Basic" complete (guide trough-sets + 1)	Order text: 17 installation sets "Basic"	Part No.	960.40.175
Module for the fixed end	Order text: 1 set	Part No.	973.80
Optional: For an additional noise dampening with silencer profile, please add Index A Example:		Part No.	973.30.SLA

Lengths of C-profile for Basic version - Bottom clamp attached optionally inwards or outwards

3500			E4.42/H4.42/R4.42			380/390/R780			3838/3938/R7838			E6.52/R6.52		
3500.050.200.0			E4.42.050.200.0			380.050.200.0			3838.050.200.0			E6.52.040.200.0		
B_{Ri} [mm]	Part No. attached inwards	Part No. attached outwards	B_{Ri} [mm]	Part No. attached inwards	Part No. attached outwards	B_{Ri} [mm]	Part No. attached inwards	Part No. attached outwards	B_{Ri} [mm]	Part No. attached inwards	Part No. attached outwards	B_{Ri} [mm]	Part No. attached inwards	Part No. attached outwards
.050	74	* 960.40.200	.05	80	* 960.40.200	.05	80	* 960.40.200	.05	81	* 960.40.200	.040	68	* 960.40.200
.075	99	* 960.40.225	.06	98	* 960.40.225	.06	98	* 960.40.225	.06	99	* 960.40.225	.050	78	* 960.40.200
.100	124	960.40.175 960.40.250	.07	105	* 960.40.225	.07	105	* 960.40.225	.07	106	* 960.40.225	.062	90	* 960.40.225
.115	139	960.40.200 960.40.275	.087	118	960.40.175 960.40.250	.087	118	960.40.175 960.40.250	.087	119	960.40.175 960.40.250	.070	98	* 960.40.225
.125	149	960.40.200 960.40.275	.10	130	960.40.200 960.40.250	.10	130	960.40.200 960.40.250	.10	131	960.40.200 960.40.250	.075	103	* 960.40.225
.150	174	960.40.225 960.40.300	.11	138	960.40.200 960.40.275	.11	138	960.40.200 960.40.275	.11	139	960.40.200 960.40.275	.087	115	* 960.40.250
.175	199	960.40.250 960.40.325	.112	143	960.40.200 960.40.275	.112	143	960.40.200 960.40.275	.112	144	960.40.200 960.40.275	.100	128	960.40.175 960.40.250
.200	224	960.40.275 960.40.350	.12	155	960.40.225 960.40.275	.12	155	960.40.225 960.40.275	.12	156	960.40.225 960.40.275	.125	153	960.40.200 960.40.275
.225	249	960.40.300 960.40.375	.137	168	960.40.225 960.40.300	.137	168	960.40.225 960.40.300	.137	169	960.40.225 960.40.300	.150	178	960.40.225 960.40.300
.250	274	960.40.325 960.40.400	.15	180	960.40.250 960.40.300	.15	180	960.40.250 960.40.300	.15	181	960.40.250 960.40.300	.175	203	960.40.250 960.40.325
			.162	193	960.40.250 960.40.325	.162	193	960.40.250 960.40.325	.162	194	960.40.250 960.40.325	.200	228	960.40.275 960.40.350
			.17	198	960.40.250 960.40.325	.17	198	960.40.250 960.40.325	.17	199	960.40.250 960.40.325	.225	253	960.40.300 960.40.375
			.18	205	960.40.275 960.40.325	.18	205	960.40.275 960.40.325	.18	206	960.40.275 960.40.325	.250	278	960.40.325 960.40.400
			.187	218	960.40.275 960.40.350	.187	218	960.40.275 960.40.350	.187	219	960.40.275 960.40.350	.275	303	960.40.350 960.40.425
			.20	230	960.40.300 960.40.350	.20	230	960.40.300 960.40.350	.20	231	960.40.300 960.40.350	.300	328	960.40.375 960.40.450
			.212	243	960.40.300 960.40.375	.212	243	960.40.300 960.40.375	.212	244	960.40.300 960.40.375			
			.23	255	960.40.325 960.40.375	.23	255	960.40.325 960.40.375	.23	256	960.40.325 960.40.375			
			.237	268	960.40.325 960.40.400	.237	268	960.40.325 960.40.400	.237	269	960.40.325 960.40.400			
			.25	280	960.40.350 960.40.400	.25	280	960.40.350 960.40.400	.25	281	960.40.350 960.40.400			
			.262	293	960.40.350 960.40.425	.262	293	960.40.350 960.40.425	.262	294	960.40.350 960.40.425			
.050	72	* 960.40.200	.28	305	960.40.375 960.40.425	.28	305	960.40.375 960.40.425	.28	306	960.40.375 960.40.425			
.075	97	* 960.40.225	.29	318	960.40.375 960.40.450	.29	318	960.40.375 960.40.450	.29	319	960.40.375 960.40.450			
.100	122	960.40.175 960.40.250	.30	330	960.40.400 960.40.450	.30	330	960.40.400 960.40.450	.30	331	960.40.400 960.40.450			
.115	137	960.40.200 960.40.275	.312	343	960.40.400 960.40.475	.312	343	960.40.400 960.40.475	.312	344	960.40.400 960.40.475			
.125	147	960.40.200 960.40.275	.325	355	960.40.425 960.40.475	.325	355	960.40.425 960.40.475	.325	356	960.40.425 960.40.475			
.150	172	960.40.225 960.40.300	.337	368	960.40.425 960.40.500	.337	368	960.40.425 960.40.500	.337	369	960.40.425 960.40.500			
.175	197	960.40.250 960.40.325	.350	380	960.40.450 960.40.500	.350	380	960.40.450 960.40.500	.350	381	960.40.450 960.40.500			
.200	222	960.40.275 960.40.350	.362	393	960.40.450 960.40.525	.362	393	960.40.450 960.40.525	.362	394	960.40.450 960.40.525			
.225	247	960.40.300 960.40.375	.375	406	960.40.475 960.40.525	.375	406	960.40.475 960.40.525	.375	406	960.40.475 960.40.525			
.250	272	960.40.325 960.40.400	.387	418	960.40.475 960.40.550	.387	418	960.40.475 960.40.550	.387	419	960.40.475 960.40.550			
			.400	430	960.40.500 960.40.550	.400	430	960.40.500 960.40.550	.400	431	960.40.500 960.40.550			

*upon request

"Heavy Duty" Version | Installation set Part No. 973.50

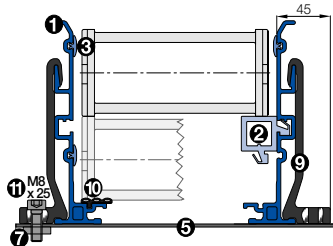

- Components, trough "Heavy Duty": ① Trough side parts, aluminum, 2 m ② Glide bar, plastic, 2 m ③ Glide strips, plastic 2 m (without glide strips on request) ⑩ Optional: Silencer profile, rubber
- Components, installation set "Heavy Duty": ⑤ C-profile, steel galvanized ⑦ Sliding nut M8 ⑧ Heavy duty bracket, aluminum ⑪ Screw M8 x 25



- = Guide trough
- = Glide bar
- = Installation set "Heavy duty"
- = C-profile

Note: Dimensions similar to Basic version!
Exception: Heavy duty bracket, see drawing

Insert for the installation set "Heavy-Duty": **973.50.XXX** instead of 960.40.XXX on the right column "attached outwards"
"Heavy Duty" installation set Part No 973.50.175

! The inner width of the guide through and the length of the C-Profile of the assembly kit can differ according to the bracket you choose. Please call us!



For the following
igus® Series

System E4

- E4.56/H4.56/R4.56
- 400/410/R880
- 4040/4140/R8840
- 14040/14140/R18840
- 14240/14340

System E6

- E6.62

B_a = Outer e-chain* width
 B_i = Inner e-chain* width
 h_a = e-chain* outer height
 H_{Ri} = Inner trough height
 H_{Ra} = Outer trough height
 B_{Ri} = Inner trough width
 depends on dim. B_a
 B_{Ra} = Outer trough width

$H_{Ri} \geq 2 \cdot h_a$
 $B_{Ri} \geq B_a + 4$

- = Guide trough
- = Glide bar
- = Installation set "Basic"
- = C-profile



Calculation - travel
center mounted

Half travel length, rounded down to full 2 m sections = X m guide trough length without glide bars + X m guide trough length with glide bars + installation sets "Basic" (number of trough pieces + 1)

Supplement Part No. with the indicated C-profile-length-index.

Example: 960.50. 200

C-profile length-index for your chosen trough inner width B_{Ri} ► see table on the right or the respective page for chosen series



Fixed end module - A quick fix for mounting the stationary end of an e-chain* ► page 9.16

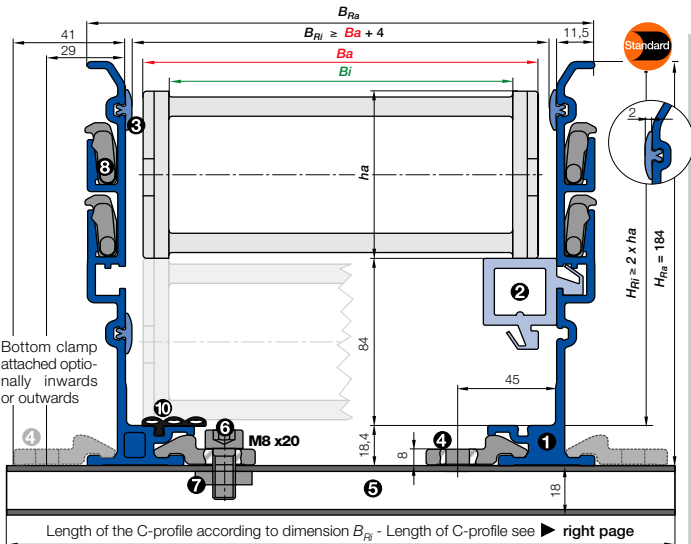

- Components, trough "Basic": ① Trough side parts, aluminum, 2 m ② Glide bar, plastic, 2 m ③ Glide strips, plastic, 2 m (without glide strips on request) ⑩ Optional: Silencer profile, rubber
- Components, installation set "Basic": ④ Bottom clamp, aluminum ⑤ C-profile, steel galvanized ⑥ Screw M8 x 20 ⑦ Sliding nut M8 ⑧ Interface connector, plastic

Basic version: Aluminum "SuperTrough" components

Complete guide trough sets - description	Part No.	Weight	kg
① Set of 2 trough side parts, incl. glide strips, without glide bars, 2 m section	974.30.SL	= 10,0 kg	
① Set of 2 trough side parts, incl. glide strips, with glide bars, 2 m section	974.31.SL	= 12,8 kg	
1 Installation set "Basic" without C-profile	960.50	= 0,08 kg	
1 Installation set "Basic" with C-profile	960.50.		
Single parts - description			
② 1 Glide strip, individual, 2 m section	75.01	= 0,06 kg	
⑩ 1 Silencer profile, rubber, individual, 2 m section	75.68.H		
④ 1 Bottom clamp, individual	75.50	= 0,04 kg	
⑧ 1 Interface connector, individual	75.60		
⑥ 1 Screw M8 x 20, individual	MAT 0040445		
⑦ 1 Sliding nut M8, individual	MAT 0040413		
② 1 Glide bar, individual, 2 m section	83.79	= 1,30 kg	
⑤ 1 C-profile, individual	92.52.	= 0,90 kg/m	



Order example: Length of travel 30 m - Center mounted for Series E4.56.10.250.0 with $B_{Ri} = 138$

Guide trough set (set of 2 trough side parts, incl. glide strips) without glide bar		
Order text: 16 m guide trough without glide bar (8 x 2 m sections)	Part No.	974.30.SL
Guide trough set (set of 2 trough side parts, incl. glide strips) with glide bar		
Order text: 16 m guide trough with glide bar (8 x 2 m sections)	Part No.	974.31.SL
Installation set "Basic" complete (guide trough-sets + 1)		
Order text: 17 installation sets "Basic"	Part No.	960.50. 200
Module for the fixed end		
Order text: 1 set	Part No.	974.80
Option: For an additional noise dampening with silencer profile, please add Index A Example:	Part No.	974.30.SLA

Lengths of C-profile for Basic version - Bottom clamp attached optionally inwards or outwards

E4.56/H4.56/R4.56			400/410/R880			4040/4140/R8840			14040/14140/R18840			14240/14340			E6.62		
E4.56.05.200.0			400.05.200.0			4040.05.200.0			14040.05.200.0			14240.05.200.0			E6.62.05.200.0		
B_{R0} [mm]	Part No. attached inwards	Part No. attached outwards	B_{R0} [mm]	Part No. attached inwards	Part No. attached outwards	B_{R0} [mm]	Part No. attached inwards	Part No. attached outwards	B_{R0} [mm]	Part No. attached inwards	Part No. attached outwards	B_{R0} [mm]	Part No. attached inwards	Part No. attached outwards	B_{R0} [mm]	Part No. attached inwards	Part No. attached outwards
.05 88	*	960.50.225	.05 88	*	960.50.225	.05 90	*	960.50.225	.05 80	*	960.50.200	05 80	*	960.50.200	05 90	*	960.50.225
.06 103	*	960.50.225	.06 103	*	960.50.225	.06 105	*	960.50.225	.06 95	*	960.50.225	.06 98	*	960.50.225	.06 108	*	960.50.225
.07 113	*	960.50.250	.07 113	*	960.50.250	.07 115	*	960.50.250	.07 105	*	960.50.225	.07 105	*	960.50.225	.07 115	*	960.50.250
.08 125	960.50.175	960.50.250	.08 125	960.50.175	960.50.250	.08 127	960.50.175	960.50.250	.08 117	960.50.175	960.50.225	.087 118	960.50.175	960.50.250	.087127	960.50.175	960.50.250
.10 138	960.50.200	960.50.275	.10 138	960.50.200	960.50.275	.10 140	960.50.200	960.50.275	.10 130	960.50.200	960.50.250	.10 130	960.50.200	960.50.250	.10 140	960.50.200	960.50.275
.11 151	960.50.200	960.50.275	.11 151	960.50.200	960.50.275	.11 153	960.50.200	960.50.275	.11 143	960.50.200	960.50.275	.11 138	960.50.200	960.50.275	.11 148	960.50.200	960.50.275
.12 163	960.50.225	960.50.300	.12 163	960.50.225	960.50.300	.12 165	960.50.225	960.50.300	.12 155	960.50.225	960.50.275	.112143	960.50.200	960.50.275	.112152	960.50.200	960.50.275
.13 176	960.50.225	960.50.300	.13 176	960.50.225	960.50.300	.13 178	960.50.225	960.50.300	.13 168	960.50.225	960.50.300	.12 155	960.50.225	960.50.275	.12 165	960.50.225	960.50.300
.15 188	960.50.250	960.50.325	.15 188	960.50.250	960.50.325	.15 190	960.50.250	960.50.325	.15 180	960.50.250	960.50.300	.137168	960.50.225	960.50.300	.137177	960.50.225	960.50.300
.16 201	960.50.250	960.50.325	.16 201	960.50.250	960.50.325	.16 203	960.50.250	960.50.325	.16 193	960.50.250	960.50.325	.15 180	960.50.250	960.50.300	.15 190	960.50.250	960.50.325
.17 213	960.50.275	960.50.350	.17 213	960.50.275	960.50.350	.17 215	960.50.275	960.50.350	.17 205	960.50.275	960.50.325	.162193	960.50.250	960.50.325	.162202	960.50.250	960.50.325
.18 226	960.50.275	960.50.350	.18 226	960.50.275	960.50.350	.18 228	960.50.275	960.50.350	.18 218	960.50.275	960.50.325	.17 198	960.50.250	960.50.325	.17 208	960.50.275	960.50.325
.20 238	960.50.300	960.50.375	.20 238	960.50.300	960.50.375	.20 240	960.50.300	960.50.375	.20 230	960.50.300	960.50.350	.18 205	960.50.275	960.50.325	.18 215	960.50.275	960.50.350
.21 251	960.50.300	960.50.375	.21 251	960.50.300	960.50.375	.21 253	960.50.300	960.50.375	.21 243	960.50.300	960.50.375	.187218	960.50.275	960.50.350	.187227	960.50.275	960.50.350
.22 263	960.50.325	960.50.400	.22 263	960.50.325	960.50.400	.22 265	960.50.325	960.50.400	.22 255	960.50.325	960.50.375	.20 230	960.50.300	960.50.350	.20 240	960.50.300	960.50.375
.23 276	960.50.325	960.50.400	.23 276	960.50.325	960.50.400	.23 278	960.50.325	960.50.400	.23 268	960.50.325	960.50.400	.212243	960.50.300	960.50.375	.212252	960.50.300	960.50.375
.25 288	960.50.350	960.50.425	.25 288	960.50.350	960.50.425	.25 290	960.50.350	960.50.425	.25 280	960.50.350	960.50.400	.23 255	960.50.325	960.50.375	.23 265	960.50.325	960.50.400
.26 301	960.50.350	960.50.425	.26 301	960.50.350	960.50.425	.26 303	960.50.350	960.50.425	.26 293	960.50.350	960.50.425	.237268	960.50.325	960.50.400	.237277	960.50.325	960.50.400
.27 313	960.50.375	960.50.450	.27 313	960.50.375	960.50.450	.27 315	960.50.375	960.50.450	.27 305	960.50.375	960.50.425	.25 280	960.50.350	960.50.400	.25 290	960.50.350	960.50.425
.28 326	960.50.375	960.50.450	.28 326	960.50.375	960.50.450	.28 328	960.50.375	960.50.450	.28 318	960.50.375	960.50.450	.262293	960.50.350	960.50.425	.262302	960.50.350	960.50.425
.30 338	960.50.400	960.50.475	.30 338	960.50.400	960.50.475	.30 340	960.50.400	960.50.475	.30 330	960.50.400	960.50.450	.28 305	960.50.375	960.50.425	.28 315	960.50.375	960.50.450
.31 351	960.50.400	960.50.475	.31 351	960.50.400	960.50.475	.31 353	960.50.400	960.50.475	.31 343	960.50.400	960.50.475	.29 318	960.50.375	960.50.450	.29 327	960.50.375	960.50.450
.32 363	960.50.425	960.50.500	.32 363	960.50.425	960.50.500	.32 365	960.50.425	960.50.500	.32 355	960.50.425	960.50.475	.30 330	960.50.400	960.50.450	.30 340	960.50.400	960.50.475
.33 376	960.50.425	960.50.500	.33 376	960.50.425	960.50.500	.33 378	960.50.425	960.50.500	.33 368	960.50.425	960.50.500	.312343	960.50.400	960.50.475	.312352	960.50.400	960.50.475
.35 388	960.50.450	960.50.525	.35 388	960.50.450	960.50.525	.35 390	960.50.450	960.50.525	.35 380	960.50.450	960.50.500	.325355	960.50.425	960.50.475	.325365	960.50.425	960.50.500
.36 401	960.50.450	960.50.525	.36 401	960.50.450	960.50.525	.36 403	960.50.450	960.50.525	.36 393	960.50.450	960.50.525	.337368	960.50.425	960.50.500	.337377	960.50.425	960.50.500
.37 413	960.50.475	960.50.550	.37 413	960.50.475	960.50.550	.37 415	960.50.475	960.50.550	.37 405	960.50.475	960.50.525	.350380	960.50.450	960.50.500	.350390	960.50.450	960.50.525
.38 426	960.50.475	960.50.550	.38 426	960.50.475	960.50.550	.38 428	960.50.475	960.50.550	.38 418	960.50.475	960.50.550	.362393	960.50.450	960.50.525	.362402	960.50.450	960.50.525
.40 438	960.50.500	960.50.575	.40 438	960.50.500	960.50.575	.40 440	960.50.500	960.50.575	.40 430	960.50.500	960.50.550	.375405	960.50.475	960.50.525	.375415	960.50.475	960.50.550
.41 451	960.50.500	960.50.575	.41 451	960.50.500	960.50.575	.41 453	960.50.500	960.50.575	.41 443	960.50.500	960.50.575	.387418	960.50.475	960.50.550	.387427	960.50.475	960.50.550
.42 463	960.50.525	960.50.600	.42 463	960.50.525	960.50.600	.42 465	960.50.525	960.50.600	.42 455	960.50.525	960.50.575	.400430	960.50.500	960.50.550	.400440	960.50.500	960.50.575
.43 476	960.50.525	960.50.600	.43 476	960.50.525	960.50.600	.43 478	960.50.525	960.50.600	.43 468	960.50.525	960.50.600						
.45 488	960.50.550	960.50.625	.45 488	960.50.550	960.50.625	.45 490	960.50.550	960.50.625	.45 480	960.50.550	960.50.600						
.46 501	960.50.550	960.50.625	.46 501	960.50.550	960.50.625	.46 503	960.50.550	960.50.625	.46 493	960.50.550	960.50.625						
.47 513	960.50.575	960.50.650	.47 513	960.50.575	960.50.650	.47 515	960.50.575	960.50.650	.47 505	960.50.575	960.50.625						
.48 526	960.50.575	960.50.650	.48 526	960.50.575	960.50.650	.48 528	960.50.575	960.50.650	.48 518	960.50.575	960.50.650						
.50 538	960.50.600	960.50.675	.50 538	960.50.600	960.50.675	.50 540	960.50.600	960.50.675	.50 530	960.50.600	960.50.650						
.51 551	960.50.600	960.50.675	.51 551	960.50.600	960.50.675	.51 553	960.50.600	960.50.675	.51 543	960.50.600	960.50.675						
.52 563	960.50.625	960.50.700	.52 563	960.50.625	960.50.700	.52 565	960.50.625	960.50.700	.52 555	960.50.625	960.50.675						
.53 576	960.50.625	960.50.700	.53 576	960.50.625	960.50.700	.53 578	960.50.625	960.50.700	.53 568	960.50.625	960.50.700						
.55 588	960.50.650	960.50.725	.55 588	960.50.650	960.50.725	.55 590	960.50.650	960.50.725	.55 580	960.50.650	960.50.700						
.60 638	960.50.700	960.50.775	.60 638	960.50.700	960.50.775	.60 640	960.50.700	960.50.775	.60 630	960.50.700	960.50.750						

*upon request

"Heavy Duty" Version | Installation set Part No. 974.50

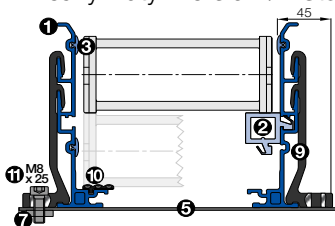

- Components, trough "Heavy Duty": ① Trough side parts, aluminum, 2 m ② Glide bar, plastic, 2 m ③ Glide strips, plastic 2 m (without glide strips on request) ⑩ Optional: Silencer profile, rubber
- Components, installation set "Heavy Duty": ⑤ C-profile, steel galvanized ⑦ Sliding nut M8 ⑧ Heavy duty bracket, aluminum ① Screw M8 x 25



- = Guide trough
- = Glide bar
- = Installation set "Heavy duty"
- = C-profile

Note: Dimensions similar to Basic version!
Exception: Heavy duty bracket, see drawing

Insert for the installation set "Heavy-Duty": **974.50.XXX** instead of 960.50.XXX on the right column "attached outwards"
"Heavy Duty" installation set Part No. 974.50. 200

! The inner width of the guide through and the length of the C-Profile of the assembly kit can differ according to the bracket you choose. Please call us!



For the following
igus® Series

System E4

- 4040HD/R8840HD

We especially recommend for the igus® E4/4 series 4040 HD (Heavy Duty) this trough system. Structurally identical with trough 974.30.SL yet with special HD-installation set, suitable for ambitious applications.

B_a = Outer e-chain* width
 B_i = Inner e-chain* width
 h_a = e-chain* outer height
 H_{Ri} = Inner trough height
 H_{Ra} = Outer trough height
 B_{Ri} = Inner trough width
depends on dim. B_a
 B_{Ra} = Outer trough width

! $H_{Ri} \geq 2 \cdot h_a$
■ $B_{Ri} \geq B_a + 4$

- = Guide trough
- = Glide bar
- = Installation set
- = C-profile



Calculation - travel
center mounted

Half travel length, rounded down to full 2 m sections = X m guide trough length without glide bars + X m guide trough length with glide bars + installation sets (number of trough pieces + 1)

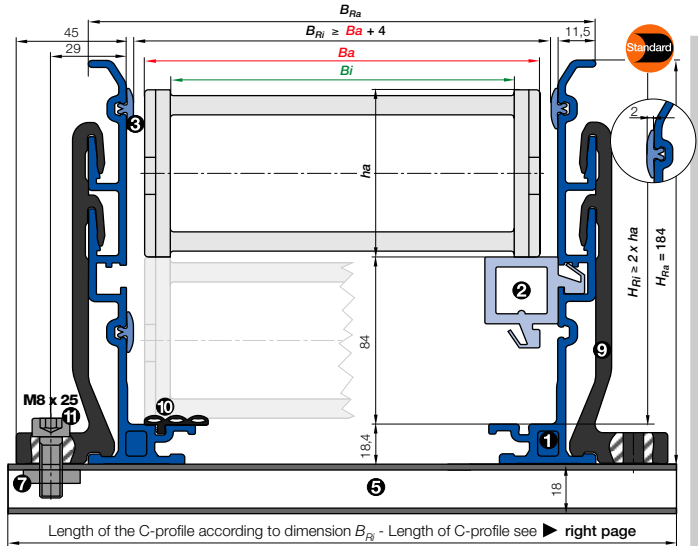

- Components, trough "Heavy Duty": ① Trough side parts, aluminum, 2 m ② Glide bar, plastic, 2 m ③ Glide strips, plastic, 2 m (without glide strips on request) ⑩ Optional: Silencer profile, rubber
- Components, installation set "Heavy Duty": ⑤ C-profile, steel galvanized ⑦ Sliding nut M8 ⑨ Heavy duty bracket, aluminum ⑪ Screw M8 x 25

Heavy Duty version: Aluminum "SuperTrough" components

Complete guide trough sets - description	Part No.	Weight	kg
① Set of 2 trough side parts, incl. glide strips, without glide bars, 2 m section	974.30.SL	= 10,0 kg	
① Set of 2 trough side parts, incl. glide strips, with glide bars, 2 m section	974.31.SL	= 12,8 kg	
⑨ 1 Installation set "Heavy Duty" without C-profile	974.50	= 0,40 kg	
1 Installation set "Heavy Duty" with C-profile	974.50.		<input type="text"/>
Single parts - description			
③ 1 Glide strip, individual, 2 m section	75.01	= 0,06 kg	
⑩ 1 Silencer profile, rubber, individual, 2 m section	75.68.H		
⑪ 1 Screw M8 x 25, individual	MAT 0040445		
⑦ 1 Sliding nut M8, individual	MAT 0040413		
② 1 Glide bar, individual, 2 m section	83.79	= 1,30 kg	
⑤ 1 C-profile, individual	92.52.	= 0,90 kg/m	<input type="text"/>



Order example: Length of travel 30 m -
Center mounted for Series 4040HD.10.250.0 with $B_{Ri} = 158$

Guide trough set (set of 2 trough side parts, incl. glide strips) without glide bar	Part No.	974.30.SL
Order text: 16 m guide trough without glide bar (8 x 2 m sections)		
Guide trough set (set of 2 trough side parts, incl. glide strips) with glide bar	Part No.	974.31.SL
Order text: 16 m guide trough with glide bar (8 x 2 m sections)		
Installation set "Heavy Duty" complete (guide trough-sets + 1)	Part No.	974.50.275
Order text: 17 installation sets "Heavy Duty"		
Option: For an additional noise dampening with silencer profile, please add Index A Example:	Part No.	974.30.SLA

Lengths of C-profile

4040HD/R8840HD

4040HD.05,250.0

B_{R1} [mm]	Part No. assembled
.05 108	974.50.225
.06 123	974.50.250
.07 133	974.50.250
.08 146	974.50.275
.10 158	974.50.275
.11 170	974.50.300
.12 183	974.50.300
.13 195	974.50.325
.15 208	974.50.325
.16 220	974.50.350
.17 233	974.50.350
.18 245	974.50.375
.20 258	974.50.375
.21 270	974.50.400
.22 283	974.50.400
.23 295	974.50.425
.25 308	974.50.425
.26 320	974.50.450
.27 333	974.50.450
.28 345	974.50.475
.30 358	974.50.475
.31 370	974.50.500
.32 383	974.50.500
.33 395	974.50.525
.35 408	974.50.525
.36 420	974.50.550
.37 433	974.50.550
.38 445	974.50.575
.40 458	974.50.575
.41 470	974.50.600
.42 483	974.50.600
.43 495	974.50.625
.45 508	974.50.625
.46 520	974.50.650
.47 533	974.50.650
.48 545	974.50.675
.50 558	974.50.675
.51 570	974.50.700
.52 583	974.50.700
.53 595	974.50.725
.55 608	974.50.725
.60 658	974.50.775



For the following
igus® Series

System E4

- E4.80/H4.80/R4.80
- 5050/5150/R9850
- 15050/15150/R19850
- 15250/15350

System E6

- E6.80

B_a = Outer e-chain* width
 B_i = Inner e-chain* width
 h_a = e-chain* outer height
 H_{Ri} = Inner trough height
 H_{Ra} = Outer trough height
 B_{Ri} = Inner trough width ►
 depends on dim. B_a
 B_{Ra} = Outer trough width

! $H_{Ri} \geq 2 \cdot h_a$
 ■ $B_{Ri} \geq B_a + 4$

- = Guide trough
- = Glide bar
- = Installation set "Basic"
- = C-profile

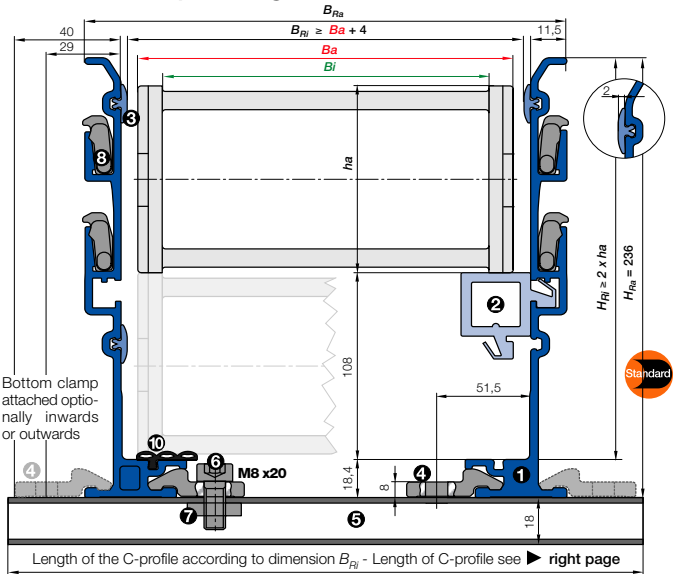

- **Components, trough "Basic":** ① Trough side parts, aluminum, 2 m ② Glide bar, plastic, 2 m ③ Glide strips, plastic, 2 m (without glide strips on request) ⑩ Optional: Silencer profile, rubber
- **Components, installation set "Basic":** ④ Bottom clamp, aluminum ⑤ C-profile, steel galvanized ⑥ Screw M8 x 20 ⑦ Sliding nut M8 ⑧ Interface connector, plastic

Basic version: Aluminum "SuperTrough" components

Complete guide trough sets - description	Part No.	Weight	kg
① Set of 2 trough side parts, incl. glide strips, without glide bars, 2 m section	975.30.SL	= 14,0 kg	
① Set of 2 trough side parts, incl. glide strips, with glide bars, 2 m section	975.31.SL	= 16,6 kg	
1 Installation set "Basic" without C-profile	960.50	= 0,08 kg	
1 Installation set "Basic" with C-profile	960.50		
Single parts - description			
③ 1 Glide strip, individual, 2 m section	75.01	= 0,06 kg	
⑩ 1 Silencer profile, rubber, individual, 2 m section	75.68.H		
④ 1 Bottom clamp, individual	75.50	= 0,04 kg	
⑧ 1 Interface connector, individual	75.60		
⑥ 1 Screw M8 x 20, individual	MAT 0040445		
⑦ 1 Sliding nut M8, individual	MAT 0040413		
② 1 Glide bar, individual, 2 m section	83.79	= 1,30 kg	
⑤ 1 C-profile, individual	92.52	= 0,90 kg/m	

Supplement Part No. with the indicated C-profile-length-index.

Example: 960.50. 200

C-profile length-index for your chosen trough inner width B_{Ri} ► see table on the right or the respective page for chosen series



Fixed end module - A quick fix for mounting the stationary end of an e-chain* ► page 9.16



Order example: Length of travel 30 m - Center mounted for Series 5050.30.300.0 with $B_{Ri} = 345$

Guide trough set (set of 2 trough side parts, incl. glide strips) without glide bar	Order text: 16 m guide trough without glide bar (8 x 2 m sections)	Part No.	975.30.SL
Guide trough set (set of 2 trough side parts, incl. glide strips) with glide bar	Order text: 16 m guide trough with glide bar (8 x 2 m sections)	Part No.	975.31.SL
Installation set "Basic" complete (guide trough-sets + 1)	Order text: 17 installation sets "Basic"	Part No.	960.50. 425
Module for the fixed end	Order text: 1 set	Part No.	975.80
Option: For an additional noise dampening with silencer profile, please add Index A Example:		Part No.	975.30.SLA

Lengths of C-profile for Basic version - Bottom clamp attached optionally inwards or outwards

E4.80/H4.80/R4.80			5050/5150/R9850			15050/15150/R19850			15250/15350			E6.80			
E4.80.05.200.0			5050.05.200.0			15050.05.200.0			15250.30.300.0			E6.80.30.300.0			
B_{Ri} [mm]	Part No. attached inwards	Part No. attached outwards	B_{Ri} [mm]	Part No. attached inwards	Part No. attached outwards	B_{Ri} [mm]	Part No. attached inwards	Part No. attached outwards	B_{Ri} [mm]	Part No. attached inwards	Part No. attached outwards	B_{Ri} [mm]	Part No. attached inwards	Part No. attached outwards	
.05	104	*	960.50.225	.06	104	*	960.50.225	.05	84	*	960.50.200	.05	80	*	960.50.200
.06	119	*	960.50.250	.06	119	*	960.50.250	.06	99	*	960.50.225	.06	119	*	960.50.250
.07	129	*	960.50.250	.07	129	*	960.50.250	.07	109	*	960.50.225	.07	105	*	960.50.225
.08	141	960.50.200	960.50.275	.08	141	960.50.200	960.50.275	.08	121	*	960.50.250	.08	118	*	960.50.250
.10	154	960.50.225	960.50.275	.10	154	960.50.225	960.50.275	.10	134	*	960.50.250	.10	130	*	960.50.250
.11	167	960.50.225	960.50.300	.11	167	960.50.225	960.50.300	.11	146	960.50.200	960.50.275	.11	138	960.50.200	960.50.275
.12	179	960.50.250	960.50.300	.12	179	960.50.250	960.50.300	.12	159	960.50.225	960.50.275	.12	143	960.50.200	960.50.275
.13	192	960.50.250	960.50.325	.13	192	960.50.250	960.50.325	.13	171	960.50.225	960.50.300	.12	155	960.50.225	960.50.275
.15	204	960.50.275	960.50.325	.15	204	960.50.275	960.50.325	.15	184	960.50.250	960.50.300	.13	168	960.50.225	960.50.300
.16	217	960.50.275	960.50.350	.16	217	960.50.275	960.50.350	.16	196	960.50.250	960.50.325	.15	180	960.50.250	960.50.300
.17	229	960.50.300	960.50.350	.17	229	960.50.300	960.50.350	.17	209	960.50.275	960.50.325	.16	193	960.50.250	960.50.325
.18	242	960.50.300	960.50.375	.18	242	960.50.300	960.50.375	.18	221	960.50.275	960.50.350	.17	198	960.50.250	960.50.325
.20	254	960.50.325	960.50.375	.20	254	960.50.325	960.50.375	.20	234	960.50.300	960.50.350	.18	205	960.50.275	960.50.325
.21	267	960.50.325	960.50.400	.21	267	960.50.325	960.50.400	.21	246	960.50.300	960.50.375	.18	218	960.50.275	960.50.350
.22	279	960.50.350	960.50.400	.22	279	960.50.350	960.50.400	.22	259	960.50.325	960.50.375	.20	230	960.50.300	960.50.350
.23	292	960.50.350	960.50.425	.23	292	960.50.350	960.50.425	.23	271	960.50.325	960.50.400	.21	243	960.50.300	960.50.375
.25	304	960.50.375	960.50.425	.25	304	960.50.375	960.50.425	.25	284	960.50.350	960.50.400	.23	255	960.50.325	960.50.375
.26	317	960.50.375	960.50.450	.26	317	960.50.375	960.50.450	.26	296	960.50.350	960.50.425	.23	268	960.50.325	960.50.400
.27	329	960.50.400	960.50.450	.27	329	960.50.400	960.50.450	.27	309	960.50.375	960.50.425	.25	280	960.50.350	960.50.400
.28	342	960.50.400	960.50.475	.28	342	960.50.400	960.50.475	.28	321	960.50.375	960.50.450	.26	293	960.50.350	960.50.425
.30	354	960.50.425	960.50.475	.30	354	960.50.425	960.50.475	.30	334	960.50.400	960.50.450	.28	305	960.50.375	960.50.425
.31	367	960.50.425	960.50.500	.31	367	960.50.425	960.50.500	.31	346	960.50.400	960.50.475	.29	318	960.50.375	960.50.450
.32	379	960.50.450	960.50.500	.32	379	960.50.450	960.50.500	.32	359	960.50.425	960.50.475	.30	330	960.50.400	960.50.450
.33	392	960.50.450	960.50.525	.33	392	960.50.450	960.50.525	.33	371	960.50.425	960.50.500	.31	343	960.50.400	960.50.475
.35	404	960.50.475	960.50.525	.35	404	960.50.475	960.50.525	.35	384	960.50.450	960.50.500	.32	355	960.50.425	960.50.475
.36	417	960.50.475	960.50.550	.36	417	960.50.475	960.50.550	.36	396	960.50.450	960.50.525	.33	368	960.50.425	960.50.500
.37	429	960.50.500	960.50.550	.37	429	960.50.500	960.50.550	.37	409	960.50.475	960.50.525	.35	380	960.50.450	960.50.500
.38	442	960.50.500	960.50.575	.38	442	960.50.500	960.50.575	.38	421	960.50.475	960.50.550	.36	393	960.50.450	960.50.525
.40	454	960.50.525	960.50.575	.40	454	960.50.525	960.50.575	.40	434	960.50.500	960.50.550	.37	405	960.50.475	960.50.525
.41	467	960.50.525	960.50.600	.41	467	960.50.525	960.50.600	.41	446	960.50.500	960.50.575	.38	418	960.50.475	960.50.550
.42	479	960.50.550	960.50.600	.42	479	960.50.550	960.50.600	.42	459	960.50.525	960.50.575	.40	430	960.50.500	960.50.550
.43	492	960.50.550	960.50.625	.43	492	960.50.550	960.50.625	.43	471	960.50.525	960.50.600				
.45	504	960.50.575	960.50.625	.45	504	960.50.575	960.50.625	.45	484	960.50.550	960.50.600				
.46	517	960.50.575	960.50.650	.46	517	960.50.575	960.50.650	.46	496	960.50.550	960.50.625				
.47	529	960.50.600	960.50.650	.47	529	960.50.600	960.50.650	.47	509	960.50.575	960.50.625				
.48	542	960.50.600	960.50.675	.48	542	960.50.600	960.50.675	.48	521	960.50.575	960.50.650				
.50	554	960.50.625	960.50.675	.50	554	960.50.625	960.50.675	.50	534	960.50.600	960.50.650				
.51	567	960.50.625	960.50.700	.51	567	960.50.625	960.50.700	.51	546	960.50.600	960.50.675				
.52	579	960.50.650	960.50.700	.52	579	960.50.650	960.50.700	.52	559	960.50.625	960.50.675				
.53	592	960.50.650	960.50.725	.53	592	960.50.650	960.50.725	.53	571	960.50.625	960.50.700				
.55	604	960.50.675	960.50.725	.55	604	960.50.675	960.50.725	.55	584	960.50.650	960.50.700				
.60	654	960.50.725	960.50.775	.60	654	960.50.725	960.50.775	.60	634	960.50.700	960.50.750				



"Heavy Duty" Version | Installation set Part No. 975.50

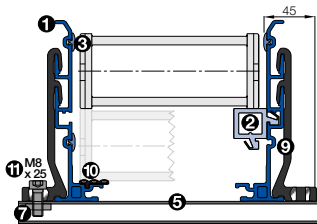

- Components, trough "Heavy Duty": ① Trough side parts, aluminum, 2 m ② Glide bar, plastic, 2 m ③ Glide strips, plastic 2 m (without glide strips on request) ⑩ Optional: Silencer profile, rubber
- Components, installation set "Heavy Duty": ⑤ C-profile, steel galvanized ⑦ Sliding nut M8 ⑧ Heavy duty bracket, aluminum ① Screw M8 x 25

Note: Dimensions similar to Basic version!
Exception: Heavy duty bracket, see drawing

- = Guide trough
- = Glide bar
- = Installation set "Heavy duty"
- = C-profile

Insert for the installation set "Heavy-Duty": **975.50.XXX** instead of 960.50.XXX on the right column "attached outwards"
"Heavy Duty" installation set Part No. 975.50. 200

! The inner width of the guide through and the length of the C-Profile of the assembly kit can differ according to the bracket you choose. Please call us!



For the following
igus® Series

System E4

- 5050HD/R9850HD

We especially recommend for the igus® E4/4 series 5050 HD (Heavy Duty) this trough system. Structurally identical with trough 975.30.SL yet with special HD-installation set, suitable for ambitious applications.

- B_a = Outer e-chain® width
 - B_i = Inner e-chain® width
 - h_a = e-chain® outer height
 - H_{Ri} = Inner trough height
 - H_{Ra} = Outer trough height
 - B_{Ri} = Inner trough width
 - B_{Ra} = Outer trough width
- depends on dim. B_a

$H_{Ri} \geq 2 \cdot h_a$
 $B_{Ri} \geq B_a + 4$

- = Guide trough
- = Glide bar
- = Installation set
- = C-profile



Calculation - travel
center mounted

Half travel length, rounded down to full 2 m sections = X m guide trough length without glide bars + X m guide trough length with glide bars + installation sets (number of trough pieces + 1)

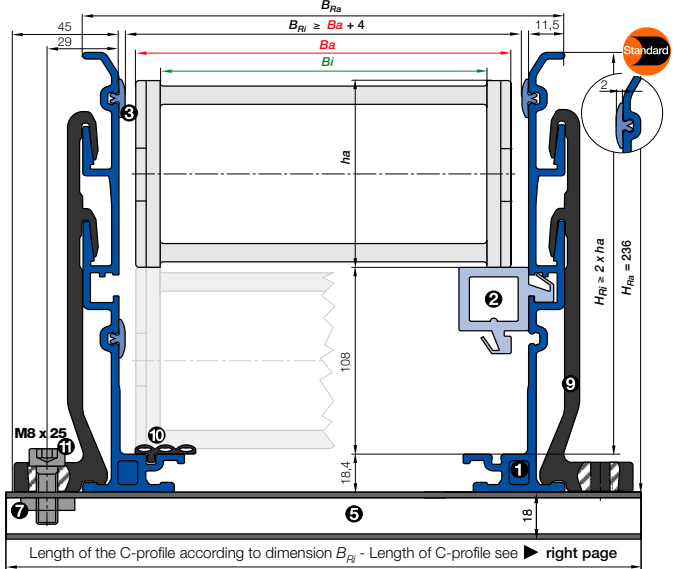

- Components, trough "Heavy Duty": ① Trough side parts, aluminum, 2 m ② Glide bar, plastic, 2 m ③ Glide strips, plastic, 2 m (without glide strips on request) ⑩ Optional: Silencer profile, rubber
- Components, installation set "Heavy Duty": ⑤ C-profile, steel galvanized ⑦ Sliding nut M8 ⑨ Heavy duty bracket, aluminum ⑪ Screw M8 x 25

Heavy Duty version: Aluminum "SuperTrough" components

Complete guide trough sets - description	Part No.	Weight	kg
① Set of 2 trough side parts, incl. glide strips, without glide bars, 2 m section	975.30.SL	= 14,0 kg	
① Set of 2 trough side parts, incl. glide strips, with glide bars, 2 m section	975.31.SL	= 16,6 kg	
⑨ 1 Installation set "Heavy Duty" without C-profile	975.50	= 0,53 kg	
1 Installation set "Heavy Duty" with C-profile	975.50.		<input type="text"/>
Single parts - description			
③ 1 Glide strip, individual, 2 m section	75.01	= 0,06 kg	
⑩ 1 Silencer profile, rubber, individual, 2 m section	75.68.H		
⑪ 1 Screw M8 x 25, individual	MAT 0040445		
⑦ 1 Sliding nut M8, individual	MAT 0040413		
② 1 Glide bar, individual, 2 m section	83.79	= 1,30 kg	
⑤ 1 C-profile, individual	92.52.	= 0,90 kg/m	<input type="text"/>



Order example: Length of travel 30 m -
Center mounted for Series 5050HD.10.250.0 with $B_{Ri} = 164$

Guide trough set (set of 2 trough side parts, incl. glide strips) without glide bar	Part No.	975.30.SL
Order text: 16 m guide trough without glide bar (8 x 2 m sections)		
Guide trough set (set of 2 trough side parts, incl. glide strips) with glide bar	Part No.	975.31.SL
Order text: 16 m guide trough with glide bar (8 x 2 m sections)		
Installation set "Heavy Duty" complete (guide trough-sets + 1)	Part No.	975.50.300
Order text: 17 installation sets "Heavy Duty"		
Option: For an additional noise dampening with silencer profile, please add Index A Example:	Part No.	975.30.SLA

Lengths of C-profile

5050HD/R9850HD

5050HD.30.300.0

B_{Rl} [mm]	Part No. assembled
.05 114	975.50.250
.06 129	975.50.250
.07 139	975.50.275
.08 152	975.50.275
.10 164	975.50.300
.11 176	975.50.300
.12 189	975.50.325
.13 201	975.50.325
.15 214	975.50.350
.16 226	975.50.350
.17 239	975.50.375
.18 251	975.50.375
.20 264	975.50.400
.21 276	975.50.400
.22 289	975.50.425
.23 301	975.50.425
.25 314	975.50.450
.26 326	975.50.450
.27 339	975.50.475
.28 351	975.50.475
.30 364	975.50.500
.31 376	975.50.500
.32 389	975.50.525
.33 401	975.50.525
.35 414	975.50.550
.36 426	975.50.550
.37 439	975.50.575
.38 451	975.50.575
.40 464	975.50.600
.41 476	975.50.600
.42 489	975.50.625
.43 501	975.50.625
.45 514	975.50.650
.46 526	975.50.650
.47 539	975.50.675
.48 551	975.50.675
.50 564	975.50.700
.51 576	975.50.700
.52 589	975.50.725
.53 601	975.50.725
.55 614	975.50.750
.60 664	975.50.800

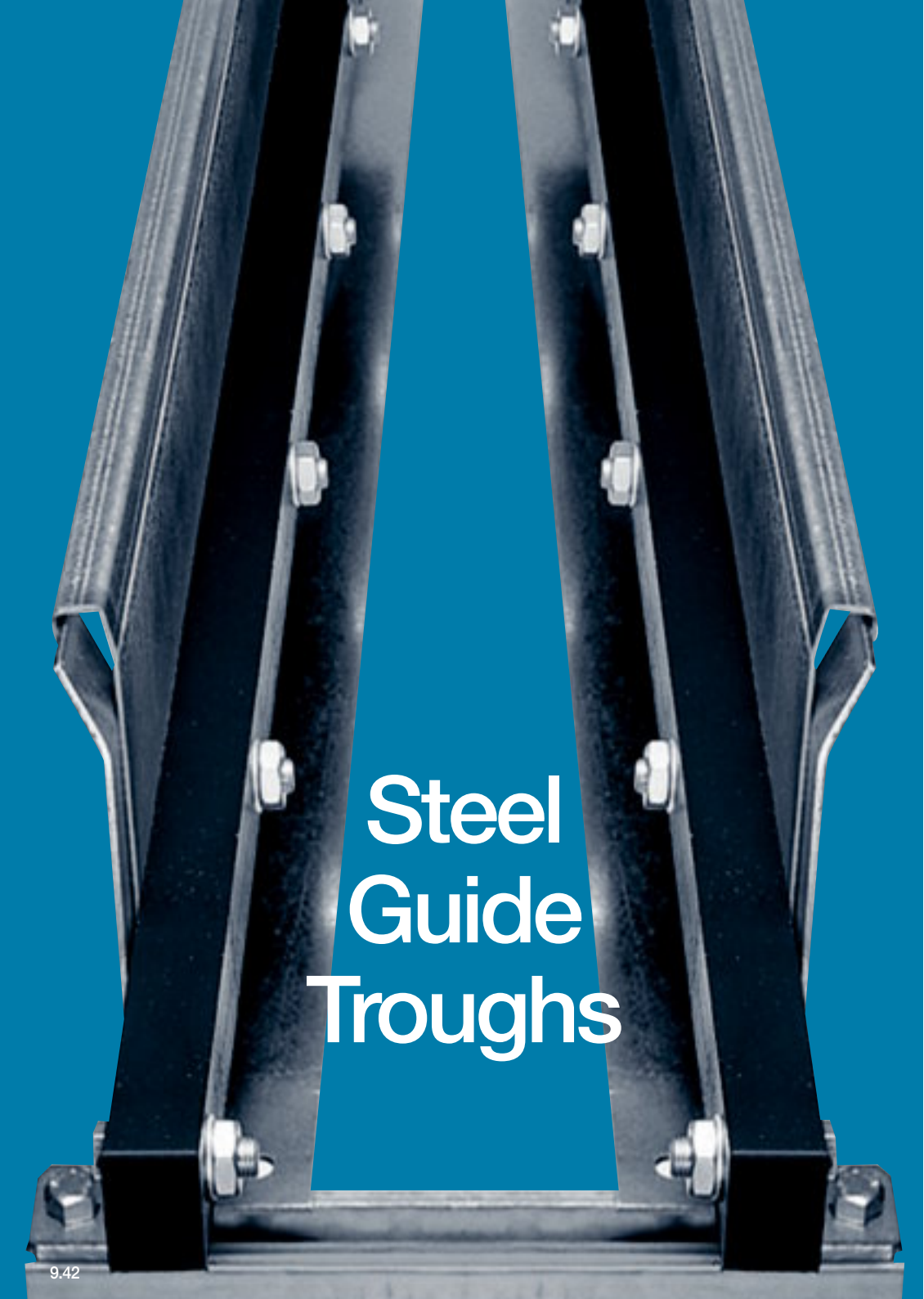

Steel Guide Troughs

Steel guide trough - very stable and rugged for heavy duty applications

If the igus® installation sets are used, the guide troughs are particularly easy to assemble. All the steel guide troughs are constructed according to the same basic principle. On the following pages, you will find information about dimensions, weights and accessories according to the trough size. You will find all necessary design data to stipulate the assembly width on. All sizes use a common C-profile on which the guide parts are assembled. The assembly brackets used vary in height only.

- Easy assembly with installation set
- Big range, two piece design, adjustable to e-chain® width
- Available in galvanized steel and stainless steel
- Glide bar made of PE

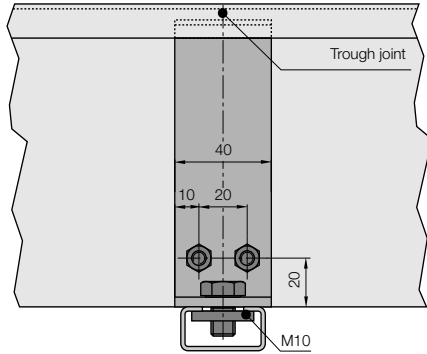

Side view of trough joint. All the dimensions, apart from the height, apply to all sizes

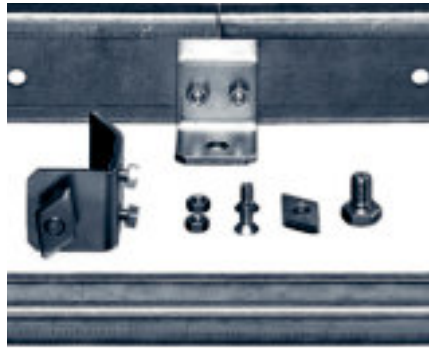

Installation set for joint and attachment surface connections secure connection without misalignment and without welding

C-profile drilling pattern

Length of the C-profile according to dimension B_{R1} ▶ Length of C-Profile

Normally galvanized version - Part No. 92.52.XX / Stainless steel version - Part No. 92.52.XX.E

Tolerance of c-profile lengths -5 mm possible



For the following
igus® Series

System E2

● 2500

● 255

System E6

● E6.29/R6.29

E2 medium classic

● 250 classic



Fixed end module

Quick installation of the mounting brackets due to the prepared bores

► page 9.62

B_a = Outer e-chain® width

B_i = Inner e-chain® width

h_a = e-chain® outer height

H_{Ri} = Inner trough height

H_{Ra} = Outer trough height

B_{Ri} = Inner trough width ►
depends on dim. B_a

B_{Ra} = Outer trough width

n_{Mon} = Number of installation sets (left/right)

n_{Ri} = Number of trough sets (left/right)

$H_{Ri} \geq 2 \cdot h_a$

$B_{Ri} \geq B_a + 5$

● = Guide trough

● = Glide bar

● = Installation set

● = C-profile

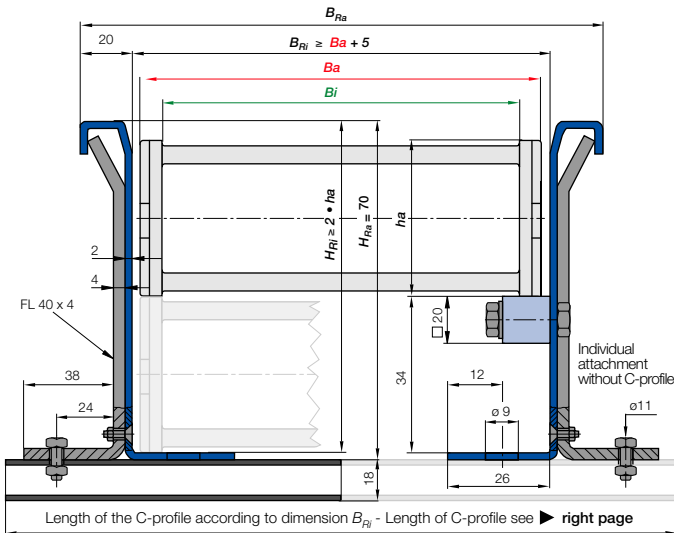

Steel Guide Trough components - Sets and single parts

Complete guide trough sets - description	Part No.	Weight	kg
Set of 2 trough side parts without glide bars, 2 m section	92.30	≈ 7,60 kg	
Set of 2 trough side parts with glide bars, 2 m section	92.31	≈ 9,60 kg	
1 Installation set with C-profile	92.50. <input type="text"/>		
1 Installation set without C-profile	92.50	≈ 0,34 kg	
Single parts - description			
1 glide bar, individual, each 2 m	92.01	≈ 0,75 kg	
1 glide bar, individual, each 2 m + 11 screw sets	92.20	≈ 0,98 kg	
11 screw sets for 2 m sections	92.21	≈ 0,23 kg	
1 Clamping bracket, individual	92.51	≈ 0,12 kg	
1 Countersunk-head screw M6 x 14, individual	92.53		
1 Hexagon nut M6, individual	92.54		
1 Hexagon-head screw M10 x 16, individual	92.55		
1 Glide nut M10, individual	92.56		
1 C-profile, individual	92.52. <input type="text"/>	≈ 0,90 kg/m	

Supplement Part No. with the indicated C-profile-length-index. Example: 92.50.

C-profile-length-index for your chosen trough inner width B_{Ri} ► right table

Trough side parts also available in stainless steel. Please add index "E" to the Part No. 92.30.E

Principle sketch: Number of installation sets which have to be installed

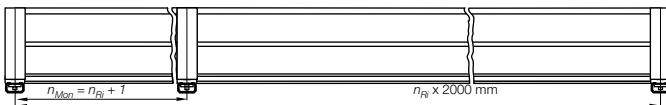

Calculation - travel
center mounted

Half travel length, rounded down to full 2 m sections = X m guide trough length without glide bars + X m guide trough length with glide bars + installation sets (number of trough pieces + 1)



Order example: Length of travel 30 m -
Center mounted for Series 2500.05.200.0 with $B_{Ri} = 78$

Guide trough-set of 2 trough side parts, without glide bars:	
16 m Guide trough = 8 x 2 m sections (without glide bars)	Part No. 92.30
Guide trough-set of 2 trough side parts, with assembled glide bars:	
16 m Guide trough = 8 x 2 m sections (with glide bars)	Part No. 92.31
Installation sets complete (Guide trough-sets + 1)	
17 Installation sets (with C-profile)	Part No. 92.50. <input type="text"/>

Part No. Installation set: Steel Guide Trough with C-profile (in dependance of the width)

2500

2500.03.200.0

B_{Rl} [mm]	Part No.	Installation set
.02	46	*
.03	59	92.50.175
.05	78	92.50.200
.07	98	92.50.225
.09	110	92.50.225
.10	124	92.50.250
.12	146	92.50.275

255

255.03.200.0

B_{Rl} [mm]	Part No.	Installation set
.03	59	92.50.175
.05	78	92.50.200
.07	98	92.50.225
.10	124	92.50.250

E6.29/R6.29

E6.29.040.100.0

B_{Rl} [mm]	Part No.	Installation set
.030	51	*
.040	61	92.50.175
.050	71	92.50.200
.060	81	92.50.200
.070	91	92.50.200
.080	101	92.50.225
.090	111	92.50.225
.100	121	92.50.250
.110	131	92.50.250
.120	141	92.50.250

*upon request



For the following
igus® Series

System E2

- 2700

System E2 e-tubes

- R58

E2 medium classic

- 27 classic



Fixed end module

Quick installation of the mounting brackets due to the prepared bores

▶ page 9.62

- B_a = Outer e-chain® width
- B_i = Inner e-chain® width
- h_a = e-chain® outer height
- H_{Ri} = Inner trough height
- H_{Ra} = Outer trough height
- B_{Ri} = Inner trough width ▶ depends on dim. B_a
- B_{Ra} = Outer trough width
- n_{Mon} = Number of installation sets (left/right)
- n_{Ri} = Number of trough sets (left/right)
- ! $H_{Ri} \geq 2 \cdot h_a$
- ! $B_{Ri} \geq B_a + 5$
- = Guide trough
- = Glide bar
- = Installation set
- = C-profile

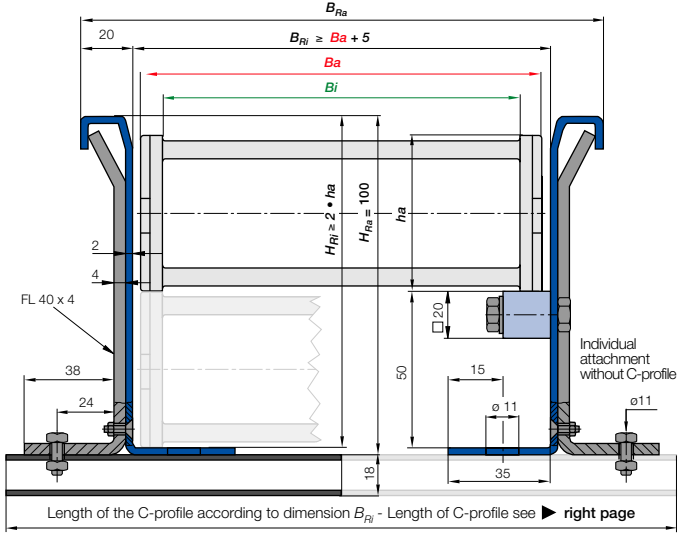

Steel Guide Trough components - Sets and single parts

Complete guide trough sets - description	Part No.	Weight	kg
Set of 2 trough side parts without glide bars, 2 m section	95.30	≈ 10,00 kg	
Set of 2 trough side parts with glide bars, 2 m section	95.31	≈ 12,00 kg	
1 Installation set with C-profile	95.50. <input type="text"/>		
1 Installation set without C-profile	95.50	≈ 0,41 kg	
Single parts - description			
1 glide bar, individual, each 2 m	92.01	≈ 0,75 kg	
1 glide bar, individual, each 2 m + 11 screw sets	92.20	≈ 0,98 kg	
11 screw sets for 2 m sections	92.21	≈ 0,23 kg	
1 Clamping bracket, individual	95.51	≈ 0,16 kg	
1 Countersunk-head screw M6 x 14, individual	92.53		
1 Hexagon nut M6, individual	92.54		
1 Hexagon-head screw M10 x 16, individual	92.55		
1 Glide nut M10, individual	92.56		
1 C-profile, individual	92.52. <input type="text"/>	≈ 0,90 kg/m	

Supplement Part No. with the indicated C-profile-length-index. Example: 95.50. 200

C-profile-length-index for your chosen trough inner width B_{Ri} ▶ right table

Trough side parts also available in stainless steel. Please add index "E" to the Part No. 95.30.E

Principle sketch: Number of installation sets which have to be installed

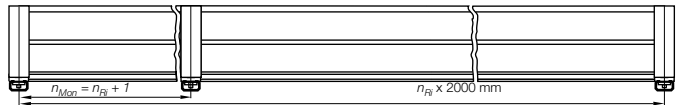

Calculation - travel
center mounted

Half travel length, rounded down to full 2 m sections = X m guide trough length without glide bars + X m guide trough length with glide bars + installation sets (number of trough pieces + 1)



Order example: Length of travel 30 m -
Center mounted for Series 2700.05.200.0 with $B_{Ri} = 71$

Guide trough-set of 2 trough side parts, without glide bars:	
16 m Guide trough = 8 x 2 m sections (without glide bars)	Part No. 95.30
Guide trough-set of 2 trough side parts, with assembled glide bars:	
16 m Guide trough = 8 x 2 m sections (with glide bars)	Part No. 95.31
Installation sets complete (Guide trough-sets + 1)	
17 Installation sets (with C-profile)	Part No. 95.50. <u>200</u>

Part No. Installation set: Steel Guide Trough with C-profile (in dependance of the width)

2700

2700.05.200.0

B_{Rl} [mm]	Part No. Installation set
.05 71	95.50.200
.06 86	95.50.200
.07 96	95.50.225
.09 111	95.50.225
.10 121	95.50.250
.12 146	95.50.275
.15 171	95.50.300
.17 199	95.50.325

R58

58.050.200.0

B_{Rl} [mm]	Part No. Installation set
.050 71	95.50.200
.075 96	95.50.225
.100 121	95.50.250
.125 146	95.50.275
.150 171	95.50.300
.175 196	95.50.325
.200 221	95.50.350



For the following
igus® Series

System E4

● E4.28/R4.28

● 220/R760

System E6
● E6.35



Fixed end module

Quick installation of the mounting brackets due to the prepared bores

▶ page 9.62

- B_a = Outer e-chain® width
- B_i = Inner e-chain® width
- h_a = e-chain® outer height
- H_{Ri} = Inner trough height
- H_{Ra} = Outer trough height
- B_{Ri} = Inner trough width ▶ depends on dim. B_a
- B_{Ra} = Outer trough width
- n_{Mon} = Number of installation sets (left/right)
- n_{Ri} = Number of trough sets (left/right)
- ! $H_{Ri} \geq 2 \cdot h_a$
- ! $B_{Ri} \geq B_a + 5$
- = Guide trough
- = Glide bar
- = Installation set
- = C-profile

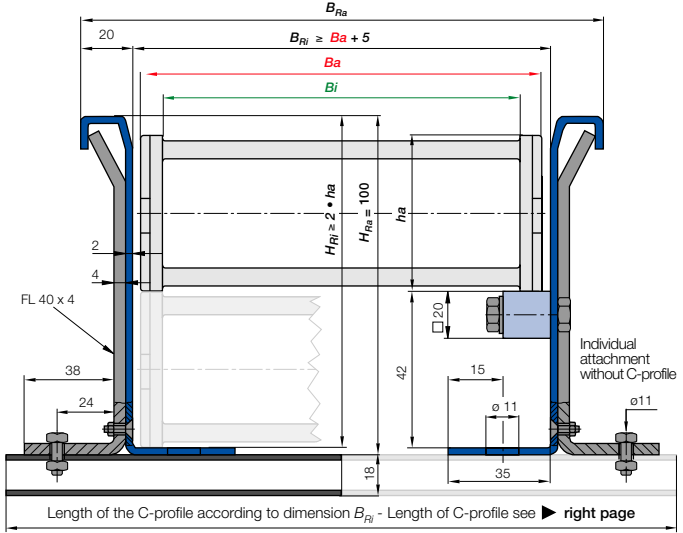

Steel Guide Trough components - Sets and single parts

Complete guide trough sets - description	Part No.	Weight	kg
Set of 2 trough side parts without glide bars, 2 m section	99.30	≈ 10,00	kg
Set of 2 trough side parts with glide bars, 2 m section	99.31	≈ 12,00	kg
1 Installation set with C-profile	95.50. <input type="text"/>		
1 Installation set without C-profile	95.50.	≈ 0,41	kg
Single parts - description			
1 glide bar, individual, each 2 m	92.01	≈ 0,75	kg
1 glide bar, individual, each 2 m + 11 screw sets	92.20	≈ 0,98	kg
11 screw sets for 2 m sections	92.21	≈ 0,23	kg
1 Clamping bracket, individual	95.51	≈ 0,16	kg
1 Countersunk-head screw M6 x 14, individual	92.53		
1 Hexagon nut M6, individual	92.54		
1 Hexagon-head screw M10 x 16, individual	92.55		
1 Glide nut M10, individual	92.56		
1 C-profile, individual	92.52. <input type="text"/>	≈ 0,90	kg/m

Supplement Part No. with the indicated C-profile-length-index. Example: 95.50.

C-profile-length-index for your chosen trough inner width B_{Ri} ▶ right table

Trough side parts also available in stainless steel. Please add index "E" to the Part No. 99.30.E

Principle sketch: Number of installation sets which have to be installed

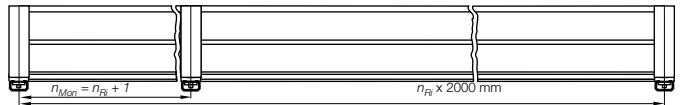

Calculation - travel
center mounted

Half travel length, rounded down to full 2 m sections = X m guide trough length without glide bars + X m guide trough length with glide bars + installation sets (number of trough pieces + 1)



Order example: Length of travel 30 m -
Center mounted for Series E4.28.050.200.0 with $B_{Ri} = 75$

Guide trough-set of 2 trough side parts, without glide bars:	
16 m Guide trough = 8 x 2 m sections (without glide bars)	Part No. 99.30
Guide trough-set of 2 trough side parts, with assembled glide bars:	
16 m Guide trough = 8 x 2 m sections (with glide bars)	Part No. 99.31
Installation sets complete (Guide trough-sets + 1)	
17 Installation sets (with C-profile)	Part No. 95.50. <input type="text" value="200"/>

Part No. Installation set: Steel Guide Trough with C-profile (in dependance of the width)

E4.28/R4.28

E4.28.**040**.200.0

B_{Rl} [mm]	Part No. Installation set
.040 65	*
.050 75	95.50.200
.062 87	95.50.200
.070 95	95.50.200
.075 100	95.50.225
.087 112	95.50.225
.100 125	95.50.250
.125 150	95.50.275
.150 175	95.50.300
.175 200	95.50.325
.200 225	95.50.350
.225 250	95.50.375
.250 275	95.50.400
.275 300	95.50.425
.300 325	95.50.450

220/R760

220.**040**.200.0

B_{Rl} [mm]	Part No. Installation set
.040 65	*
.050 75	95.50.200
.062 87	95.50.200
.070 95	95.50.200
.075 100	95.50.225
.087 112	95.50.225
.100 125	95.50.250
.125 150	95.50.275
.150 175	95.50.300
.175 200	95.50.325
.200 225	95.50.350
.225 250	95.50.375
.250 275	95.50.400
.275 300	95.50.425
.300 325	95.50.450

E6.35

E6.35.**100**.055.0

B_{Rl} [mm]	Part No. Installation set
.030 55	*
.040 65	*
.050 75	95.50.200
.060 85	95.50.200
.070 95	95.50.200
.080 105	95.50.225
.090 115	95.50.225
.100 125	95.50.250
.110 135	95.50.250
.120 145	95.50.250

*upon request



For the following
igus® Series

System E4

- E4.32/H4.32/R4.32
- 280/290/R770
- 2828/2928/R7728

System E6

- E6.40/R6.40



Fixed end module

Quick installation of the mounting brackets due to the prepared bores

► page 9.62

- B_a = Outer e-chain® width
- B_i = Inner e-chain® width
- h_a = e-chain® outer height
- H_{Ri} = Inner trough height
- H_{Ra} = Outer trough height
- B_{Ri} = Inner trough width ► depends on dim. B_a
- B_{Ra} = Outer trough width
- n_{Mon} = Number of installation sets (left/right)
- n_{Ri} = Number of trough sets (left/right)
- ! $H_{Ri} \geq 2 \cdot h_a$
- ! $B_{Ri} \geq B_a + 5$
- = Guide trough
- = Glide bar
- = Installation set
- = C-profile

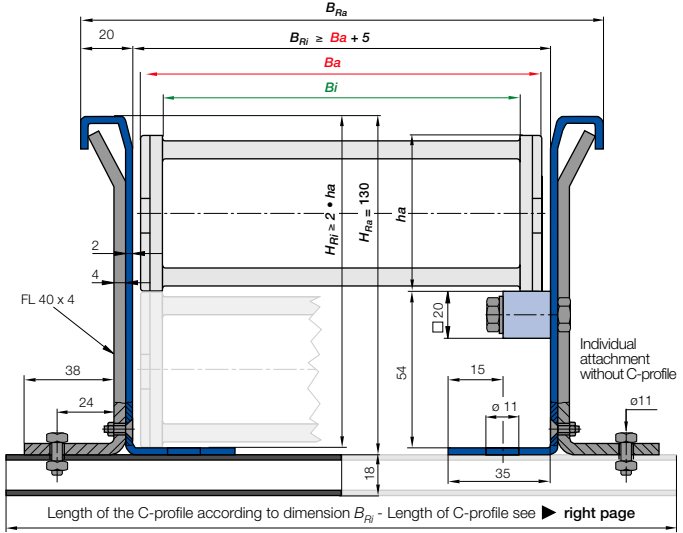

Steel Guide Trough components - Sets and single parts

Complete guide trough sets - description	Part No.	Weight	kg
Set of 2 trough side parts without glide bars, 2 m section	97.30	≈ 11,80 kg	
Set of 2 trough side parts with glide bars, 2 m section	97.31	≈ 13,60 kg	
1 Installation set with C-profile	93.50. <input type="text"/>		
1 Installation set without C-profile	93.50	≈ 0,49 kg	
Single parts - description			
1 glide bar, individual, each 2 m	92.01	≈ 0,75 kg	
1 glide bar, individual, each 2 m + 11 screw sets	92.20	≈ 0,98 kg	
11 screw sets for 2 m sections	92.21	≈ 0,23 kg	
1 Clamping bracket, individual	93.51	≈ 0,20 kg	
1 Countersunk-head screw M6 x 14, individual	92.53		
1 Hexagon nut M6, individual	92.54		
1 Hexagon-head screw M10 x 16, individual	92.55		
1 Glide nut M10, individual	92.56		
1 C-profile, individual	92.52. <input type="text"/>	≈ 0,90 kg/m	

Supplement Part No. with the indicated C-profile-length-index. **Example: 93.50. 200**

C-profile-length-index for your chosen trough inner width B_{Ri} ► right table

Trough side parts also available in stainless steel. Please add index "E" to the **Part No. 97.30.E**

Principle sketch: Number of installation sets which have to be installed

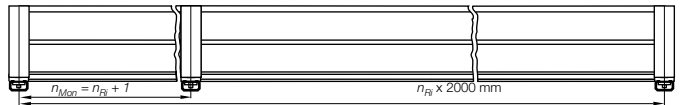

Calculation - travel
center mounted

Half travel length, rounded down to full 2 m sections = X m guide trough length without glide bars + X m guide trough length with glide bars + installation sets (number of trough pieces + 1)



Order example: Length of travel 30 m -
Center mounted for Series 2828.05.200.0 with $B_{Ri} = 79$

Guide trough-set of 2 trough side parts, without glide bars:	
16 m Guide trough = 8 x 2 m sections (without glide bars)	Part No. 97.30
Guide trough-set of 2 trough side parts, with assembled glide bars:	
16 m Guide trough = 8 x 2 m sections (with glide bars)	Part No. 97.31
Installation sets complete (Guide trough-sets + 1)	
17 Installation sets (with C-profile)	Part No. 93.50. <input type="text"/> 200



For the following
igus® Series

System E2

- 3500

System E2 e-tubes

- R68

System E4

- E4.42/H4.42/R4.42
- 380/390/R780
- 3838/3938/R7838

System E6

- E6.52/R6.52
- E2 medium classic**
- 350 classic



Fixed end module

Quick installation of the mounting brackets due to the prepared bores
▶ page 9.62

- B_a = Outer e-chain® width
- B_i = Inner e-chain® width
- h_a = e-chain® outer height
- H_{Ri} = Inner trough height
- H_{Ra} = Outer trough height
- B_{Ri} = Inner trough width ▶ depends on dim. B_a
- B_{Ra} = Outer trough width
- n_{Mon} = Number of installation sets (left/right)
- n_{Ri} = Number of trough sets (left/right)
- ! $H_{Ri} \geq 2 \cdot h_a$
- ! $B_{Ri} \geq B_a + 5$
- = Guide trough
- = Glide bar
- = Installation set
- = C-profile

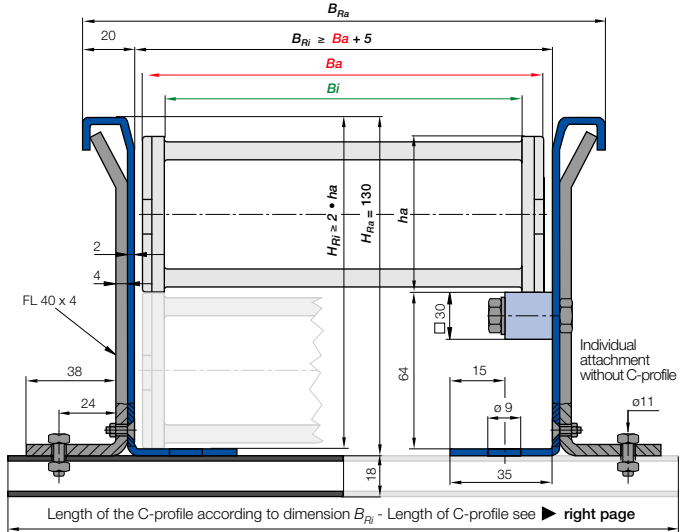

Steel Guide Trough components - Sets and single parts

Complete guide trough sets - description	Part No.	Weight	kg
Set of 2 trough side parts without glide bars, 2 m section	93.30	≈ 11,80 kg	
Set of 2 trough side parts with glide bars, 2 m section	93.31	≈ 16,20 kg	
1 Installation set with C-profile	93.50. <input type="text"/>		
1 Installation set without C-profile	93.50	≈ 0,49 kg	
Single parts - description			
1 glide bar, individual, each 2 m	93.01	≈ 1,68 kg	
1 glide bar, individual, each 2 m + 11 screw sets	93.20	≈ 2,22 kg	
11 screw sets for 2 m sections	93.21	≈ 0,54 kg	
1 Clamping bracket, individual	93.51	≈ 0,20 kg	
1 Countersunk-head screw M6 x 14, individual	92.53		
1 Hexagon nut M6, individual	92.54		
1 Hexagon-head screw M10 x 16, individual	92.55		
1 Glide nut M10, individual	92.56		
1 C-profile, individual	92.52. <input type="text"/>	≈ 0,90 kg/m	

Supplement Part No. with the indicated C-profile-length-index. **Example: 93.50. 225**

C-profile-length-index for your chosen trough inner width B_{Ri} ▶ **right table**

Trough side parts also available in stainless steel. Please add index "E" to the **Part No. 93.30.E**

Principle sketch: Number of installation sets which have to be installed

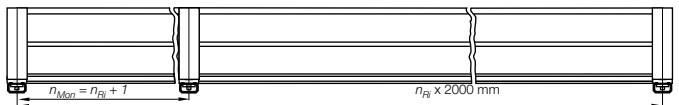

Calculation - travel
center mounted

Half travel length, rounded down to full 2 m sections = X m guide trough length without glide bars + X m guide trough length with glide bars + installation sets (number of trough pieces + 1)



Order example: Length of travel 30 m -
Center mounted for Series 3500.075.200.0 with $B_{Ri} = 100$

Guide trough-set of 2 trough side parts, without glide bars:	
16 m Guide trough = 8 x 2 m sections (without glide bars)	Part No. 93.30
Guide trough-set of 2 trough side parts, with assembled glide bars:	
16 m Guide trough = 8 x 2 m sections (with glide bars)	Part No. 93.31
Installation sets complete (Guide trough-sets + 1)	
17 Installation sets (with C-profile)	Part No. 93.50. <input type="text"/> 225

Part No. Installation set: Steel Guide Trough with C-profile (in dependence of the width)

3500			E4.42/H4.42/R4.42			380/390/R780			3838/3938/R7838			E6.52/R6.52		
3500.050.200.0			E4.42.07.200.0			390.07.200.0			3838.05.200.0			E6.52.040.200.0		
B_{Rl} [mm]	Part No.	Installation set	B_{Rl} [mm]	Part No.	Installation set	B_{Rl} [mm]	Part No.	Installation set	B_{Rl} [mm]	Part No.	Installation set	B_{Rl} [mm]	Part No.	Installation set
.050	75	93.50.200	.05	81	93.50.200	.05	81	93.50.200	.05	82	93.50.200	.040	69	*
.075	100	93.50.225	.06	99	93.50.225	.06	99	93.50.225	.06	100	93.50.225	.050	79	93.50.200
.100	125	93.50.250	.07	106	93.50.225	.07	106	93.50.225	.07	107	93.50.225	.062	91	93.50.200
.115	140	93.50.250	.087	119	93.50.250	.087	119	93.50.250	.087	120	93.50.250	.070	99	93.50.225
.125	150	93.50.275	.10	131	93.50.250	.10	131	93.50.250	.10	132	93.50.250	.075	104	93.50.225
.150	175	93.50.300	.11	139	93.50.250	.11	139	93.50.250	.11	140	93.50.250	.087	116	93.50.225
.175	200	93.50.325	.112	144	93.50.275	.112	144	93.50.275	.112	145	93.50.275	.100	129	93.50.250
.200	225	93.50.350	.12	156	93.50.275	.12	156	93.50.275	.12	157	93.50.275	.125	154	93.50.250
.225	250	93.50.375	.137	169	93.50.300	.137	169	93.50.300	.137	170	93.50.300	.150	179	93.50.300
.250	275	93.50.400	.15	181	93.50.300	.15	181	93.50.300	.15	182	93.50.300	.175	204	93.50.325
			.162	194	93.50.325	.162	194	93.50.325	.162	195	93.50.325	.200	229	93.50.350
			.17	199	93.50.325	.17	199	93.50.325	.17	200	93.50.325	.225	254	93.50.375
			.18	206	93.50.325	.18	206	93.50.325	.18	207	93.50.325	.250	279	93.50.400
			.187	219	93.50.350	.187	219	93.50.350	.187	220	93.50.350	.275	304	93.50.425
			.20	231	93.50.350	.20	231	93.50.350	.20	232	93.50.350	.300	329	93.50.450
			.212	244	93.50.375	.212	244	93.50.375	.212	245	93.50.375			
			.23	256	93.50.375	.23	256	93.50.375	.23	257	93.50.375			
			.237	269	93.50.400	.237	269	93.50.400	.237	270	93.50.400			
			.25	281	93.50.400	.25	281	93.50.400	.25	282	93.50.400			
			.262	294	93.50.425	.262	294	93.50.425	.262	295	93.50.425			
			.28	306	93.50.425	.28	306	93.50.425	.28	307	93.50.425			
			.29	319	93.50.450	.29	319	93.50.450	.29	320	93.50.450			
			.30	331	93.50.450	.30	331	93.50.450	.30	332	93.50.450			
			.312	344	93.50.475	.312	344	93.50.475	.312	345	93.50.475			
			.325	356	93.50.475	.325	356	93.50.475	.325	357	93.50.475			
			.337	369	93.50.500	.337	369	93.50.500	.337	370	93.50.500			
			.350	381	93.50.500	.350	381	93.50.500	.350	382	93.50.500			
			.362	394	93.50.525	.362	394	93.50.525	.362	395	93.50.525			
			.375	407	93.50.525	.375	407	93.50.525	.375	407	93.50.525			
			.387	419	93.50.550	.387	419	93.50.550	.387	420	93.50.550			
			.400	431	93.50.550	.400	431	93.50.550	.400	432	93.50.550			

*upon request



For the following
igus® Series

System E4

- E4.56/H4.56/R4.56
- 400/410/R880
- 4040/4140/R8840
- 4040HD/R8840HD
- 14040/14140/R18840
- 14240/14340

System E6

- E6.62



Fixed end module

Quick installation of the mounting brackets due to the prepared bores

► page 9.62

- B_a = Outer e-chain® width
- B_i = Inner e-chain® width
- h_a = e-chain® outer height
- H_{Ri} = Inner trough height
- H_{Ra} = Outer trough height
- B_{Ri} = Inner trough width ► depends on dim. B_a
- B_{Ra} = Outer trough width
- n_{Mon} = Number of installation sets (left/right)
- n_{Ri} = Number of trough sets (left/right)
- ! $H_{Ri} \geq 2 \cdot h_a$
- ! $B_{Ri} \geq B_a + 5$
- = Guide trough
- = Glide bar
- = Installation set
- = C-profile

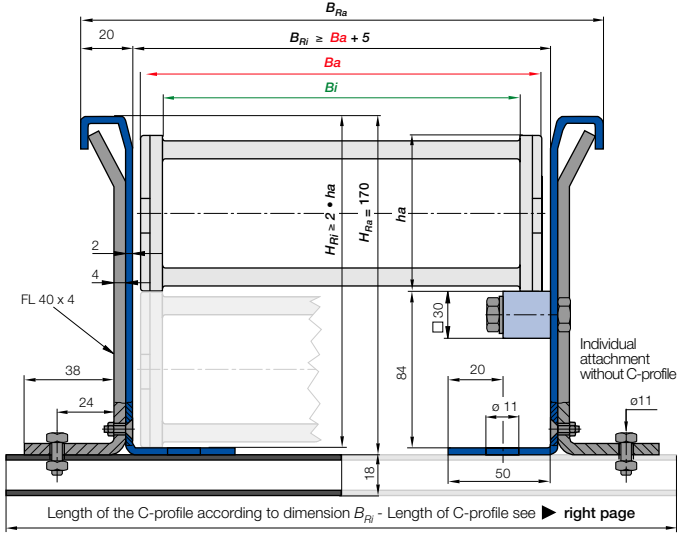

Steel Guide Trough components - Sets and single parts

Complete guide trough sets - description	Part No.	Weight	kg
Set of 2 trough side parts without glide bars, 2 m section	94.30	≈ 14,70 kg	
Set of 2 trough side parts with glide bars, 2 m section	94.31	≈ 19,00 kg	
1 Installation set with C-profile	94.50. <input type="text"/>		
1 Installation set without C-profile	94.50	≈ 0,58 kg	
Single parts - description			
1 glide bar, individual, each 2 m	93.01	≈ 1,68 kg	
1 glide bar, individual, each 2 m + 11 screw sets	93.20	≈ 2,22 kg	
11 screw sets for 2 m sections	93.21	≈ 0,54 kg	
1 Clamping bracket, individual	94.51	≈ 0,25 kg	
1 Countersunk-head screw M6 x 14, individual	92.53		
1 Hexagon nut M6, individual	92.54		
1 Hexagon-head screw M10 x 16, individual	92.55		
1 Glide nut M10, individual	92.56		
1 C-profile, individual	92.52. <input type="text"/>	≈ 0,90 kg/m	

Supplement Part No. with the indicated C-profile-length-index. Example: 94.50.

C-profile-length-index for your chosen trough inner width B_{Ri} ► right table

Trough side parts also available in stainless steel. Please add index "E" to the Part No. 94.30.E

Principle sketch: Number of installation sets which have to be installed

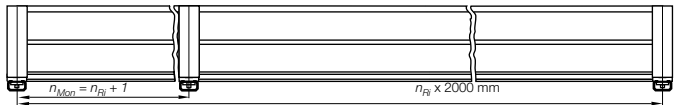

Calculation - travel
center mounted

Half travel length, rounded down to full 2 m sections = X m guide trough length without glide bars + X m guide trough length with glide bars + installation sets (number of trough pieces + 1)



Order example: Length of travel 30 m -
Center mounted for Series E4.56.06.200.0 with $B_{Ri} = 104$

Guide trough-set of 2 trough side parts, without glide bars:	
16 m Guide trough = 8 x 2 m sections (without glide bars)	Part No. 94.30
Guide trough-set of 2 trough side parts, with assembled glide bars:	
16 m Guide trough = 8 x 2 m sections (with glide bars)	Part No. 94.31
Installation sets complete (Guide trough-sets + 1)	
17 Installation sets (with C-profile)	Part No. 94.50. <input type="text" value="225"/>

Part No. Installation set: Steel Guide Trough with C-profile (in dependence of the width)

E4.56/H4.56/R4.56		400/410/R880		4040/4140/R8840		4040HD/R8840HD		14040/14140/R18840		14240/14340		E6.62	
E4.56.10.200.0		400.10.200.0		4040.05.200.0		4040HD.05.200.0		14040.05.200.0		14240.05.200.0		E6.62.05.200.0	
B_{Ri} [mm]	Part No. Installation set	B_{Ri} [mm]	Part No. Installation set	B_{Ri} [mm]	Part No. Installation set	B_{Ri} [mm]	Part No. Installation set	B_{Ri} [mm]	Part No. Installation set	B_{Ri} [mm]	Part No. Installation set	B_{Ri} [mm]	Part No. Installation set
.05	89 *	.05	89 *	.05	91 *	.05	109 94.50.225	.05	81 *	.05	81 *	.05	91 *
.06	104 94.50.225	.06	104 94.50.225	.06	106 94.50.225	.06	124 94.50.250	.06	96 *	.06	99 *	.06	109 94.50.225
.07	114 94.50.225	.07	114 94.50.225	.07	116 94.50.225	.07	134 94.50.250	.07	106 94.50.225	.07	106 94.50.225	.07	116 94.50.225
.10	139 94.50.250	.10	139 94.50.250	.10	141 94.50.250	.10	159 94.50.275	.10	131 94.50.250	.087	119 94.50.250	.087	128 94.50.250
.11	152 94.50.275	.11	152 94.50.275	.11	154 94.50.275	.11	171 94.50.300	.11	144 94.50.275	.10	131 94.50.250	.10	141 94.50.250
.12	164 94.50.275	.12	164 94.50.275	.12	166 94.50.275	.12	184 94.50.300	.12	156 94.50.275	.11	139 94.50.250	.11	149 94.50.275
.13	177 94.50.300	.13	177 94.50.300	.13	179 94.50.300	.13	196 94.50.325	.13	169 94.50.300	.112	144 94.50.275	.112	153 94.50.275
.15	189 94.50.300	.15	189 94.50.300	.15	191 94.50.300	.15	209 94.50.325	.15	181 94.50.300	.12	156 94.50.275	.12	166 94.50.275
.16	202 94.50.325	.16	202 94.50.325	.16	204 94.50.325	.16	221 94.50.350	.16	194 94.50.325	.137	169 94.50.300	.137	178 94.50.300
.17	214 94.50.325	.17	214 94.50.325	.17	216 94.50.325	.17	234 94.50.350	.17	206 94.50.325	.15	181 94.50.300	.15	191 94.50.300
.18	227 94.50.350	.18	227 94.50.350	.18	229 94.50.350	.18	246 94.50.375	.18	219 94.50.350	.162	194 94.50.325	.162	203 94.50.325
.20	239 94.50.350	.20	239 94.50.350	.20	241 94.50.350	.20	259 94.50.375	.20	231 94.50.350	.17	199 94.50.325	.17	209 94.50.325
.21	252 94.50.375	.21	252 94.50.375	.21	254 94.50.375	.21	271 94.50.400	.21	244 94.50.375	.18	206 94.50.325	.18	216 94.50.325
.22	264 94.50.375	.22	264 94.50.375	.22	266 94.50.375	.22	284 94.50.400	.22	256 94.50.375	.187	219 94.50.350	.187	228 94.50.350
.23	277 94.50.400	.23	277 94.50.400	.23	279 94.50.400	.23	296 94.50.425	.23	269 94.50.400	.20	231 94.50.350	.20	241 94.50.350
.25	289 94.50.400	.25	289 94.50.400	.25	291 94.50.400	.25	309 94.50.425	.25	281 94.50.400	.212	244 94.50.375	.212	253 94.50.375
.26	302 94.50.425	.26	302 94.50.425	.26	304 94.50.425	.26	321 94.50.450	.26	294 94.50.425	.23	256 94.50.375	.23	266 94.50.375
.27	314 94.50.425	.27	314 94.50.425	.27	316 94.50.425	.27	334 94.50.450	.27	306 94.50.425	.237	269 94.50.400	.237	278 94.50.400
.28	327 94.50.450	.28	327 94.50.450	.28	329 94.50.450	.28	346 94.50.475	.28	319 94.50.450	.25	281 94.50.400	.25	291 94.50.400
.30	339 94.50.450	.30	339 94.50.450	.30	341 94.50.450	.30	359 94.50.475	.30	331 94.50.450	.262	294 94.50.425	.262	303 94.50.425
.31	352 94.50.475	.31	352 94.50.475	.31	354 94.50.475	.31	371 94.50.500	.31	344 94.50.475	.28	306 94.50.425	.28	316 94.50.425
.32	364 94.50.475	.32	364 94.50.475	.32	366 94.50.475	.32	384 94.50.500	.32	356 94.50.475	.29	319 94.50.450	.29	328 94.50.450
.33	377 94.50.500	.33	377 94.50.500	.33	379 94.50.500	.33	396 94.50.525	.33	369 94.50.500	.30	331 94.50.450	.30	341 94.50.450
.35	389 94.50.500	.35	389 94.50.500	.35	391 94.50.500	.35	409 94.50.525	.35	381 94.50.500	.312	344 94.50.475	.312	353 94.50.475
.36	402 94.50.525	.36	402 94.50.525	.36	404 94.50.525	.36	421 94.50.550	.36	394 94.50.525	.325	356 94.50.475	.325	366 94.50.475
.37	414 94.50.525	.37	414 94.50.525	.37	416 94.50.525	.37	434 94.50.550	.37	406 94.50.525	.337	369 94.50.500	.337	378 94.50.500
.38	427 94.50.550	.38	427 94.50.550	.38	429 94.50.550	.38	446 94.50.575	.38	419 94.50.550	.350	381 94.50.500	.350	391 94.50.500
.40	439 94.50.550	.40	439 94.50.550	.40	441 94.50.550	.40	459 94.50.575	.40	431 94.50.550	.362	394 94.50.525	.362	403 94.50.525
.41	452 94.50.575	.41	452 94.50.575	.41	454 94.50.575	.41	471 94.50.600	.41	444 94.50.575	.375	406 94.50.525	.375	416 94.50.525
.42	464 94.50.575	.42	464 94.50.575	.42	466 94.50.575	.42	484 94.50.600	.42	456 94.50.575	.384	419 94.50.550	.384	428 94.50.550
.43	477 94.50.600	.43	477 94.50.600	.43	479 94.50.600	.43	496 94.50.625	.43	469 94.50.600	.400	431 94.50.550	.400	441 94.50.550
.45	489 94.50.600	.45	489 94.50.600	.45	491 94.50.600	.45	509 94.50.625	.45	481 94.50.600				
.46	502 94.50.625	.46	502 94.50.625	.46	504 94.50.625	.46	521 94.50.650	.46	494 94.50.625				
.47	514 94.50.625	.47	514 94.50.625	.47	516 94.50.625	.47	534 94.50.650	.47	506 94.50.625				
.48	527 94.50.650	.48	527 94.50.650	.48	529 94.50.650	.48	546 94.50.675	.48	519 94.50.650				
.50	539 94.50.650	.50	539 94.50.650	.50	541 94.50.650	.50	559 94.50.675	.50	531 94.50.650				
.51	552 94.50.675	.51	552 94.50.675	.51	554 94.50.675	.51	571 94.50.700	.51	544 94.50.675				
.52	564 94.50.675	.52	564 94.50.675	.52	566 94.50.675	.52	584 94.50.700	.52	556 94.50.675				
.53	577 94.50.700	.53	577 94.50.700	.53	579 94.50.700	.53	596 94.50.725	.53	569 94.50.700				
.55	589 94.50.700	.55	589 94.50.700	.55	591 94.50.700	.55	609 94.50.725	.55	581 94.50.700				
.60	639 94.50.750	.60	639 94.50.750	.60	641 94.50.750	.60	659 94.50.775	.60	631 94.50.750				

*upon request



Trough (Part No. 94.30 and 94.31)
with reinforced mounting angles for
very rugged and extreme applications

! The inner width of the guide trough and the length of the C-Profile of the assembly kit can differ according to the bracket you choose. Please call us!



For the following
igus® Series

System E4

- E4.80/H4.80/R4.80
- 5050/5150/R9850
- 5050HD/R9850HD
- 15050/15150/R19850

System E6

- E6.80



Fixed end module

Quick installation of the mounting brackets due to the prepared bores

► page 9.62

B_a = Outer e-chain® width

B_i = Inner e-chain® width

h_a = e-chain® outer height

H_{Ri} = Inner trough height

H_{Ra} = Outer trough height

B_{Ri} = Inner trough width ►
depends on dim. B_a

B_{Ra} = Outer trough width

n_{Mon} = Number of installation sets (left/right)

n_{Ri} = Number of trough sets (left/right)

$H_{Ri} \geq 2 \cdot h_a$

$B_{Ri} \geq B_a + 5$

● = Guide trough

○ = Glide bar

● = Installation set

● = C-profile

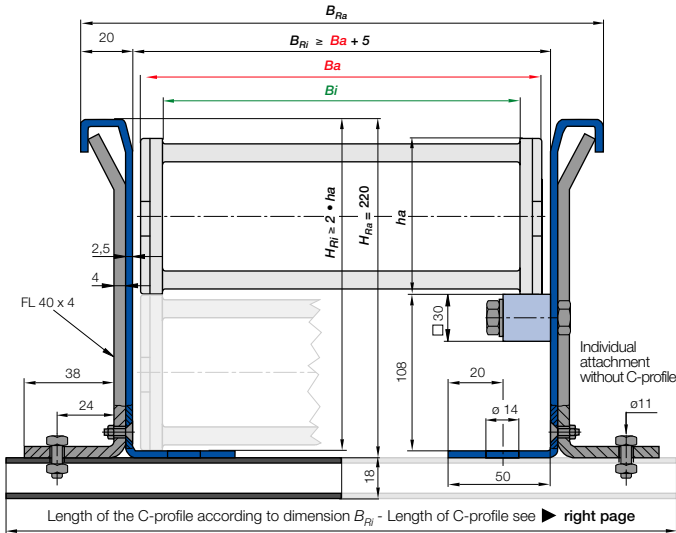

Steel Guide Trough components - Sets and single parts

Complete guide trough sets - description

Complete guide trough sets - description	Part No.	Weight	kg
Set of 2 trough side parts without glide bars, 2 m section	96.30	≈ 22,80 kg	
Set of 2 trough side parts with glide bars, 2 m section	96.31	≈ 27,20 kg	
1 Installation set with C-profile	96.50. <input type="text"/>		
1 Installation set without C-profile	96.50	≈ 0,72 kg	

Single parts - description

1 glide bar, individual, each 2 m	93.01	≈ 1,68 kg
1 glide bar, individual, each 2 m + 11 screw sets	93.20	≈ 2,22 kg
11 screw sets for 2 m sections	93.21	≈ 0,54 kg
1 Clamping bracket, individual	96.51	≈ 0,31 kg
1 Countersunk-head screw M6 x 14, individual	92.53	
1 Hexagon nut M6, individual	92.54	
1 Hexagon-head screw M10 x 16, individual	92.55	
1 Glide nut M10, individual	92.56	
1 C-profile, individual	92.52. <input type="text"/>	≈ 0,90 kg/m

Supplement Part No. with the indicated C-profile-length-index. **Example: 96.50.225**

C-profile-length-index for your chosen trough inner width B_{Ri} ► right table

Trough side parts also available in stainless steel. Please add index "E" to the **Part No. 96.30.E**

Principle sketch: Number of installation sets which have to be installed

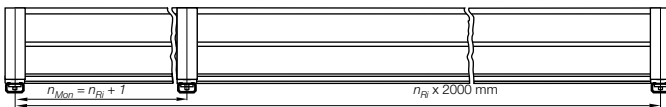

Calculation - travel
center mounted

Half travel length, rounded down to full 2 m sections = X m guide trough length without glide bars + X m guide trough length with glide bars + installation sets (number of trough pieces + 1)



Order example: Length of travel 30 m -
Center mounted for Series 5050.05.200.0 with $B_{Ri} = 105$

Guide trough-set of 2 trough side parts, without glide bars:	
16 m Guide trough = 8 x 2 m sections (without glide bars)	Part No. 96.30
Guide trough-set of 2 trough side parts, with assembled glide bars:	
16 m Guide trough = 8 x 2 m sections (with glide bars)	Part No. 96.31
Installation sets complete (Guide trough-sets + 1)	
17 Installation sets (with C-profile)	Part No. 96.50.225

Part No. Installation set: Steel Guide Trough with C-profile (in dependence of the width)

E4.80/H4.80/R4.80			5050/5150/R9850			5050HD/R9850HD			15050/15150/R19850			E6.80		
E4.80.10.200.0			5050.10.200.0			5050HD.10.200.0			15050.07.200.0			E6.80.05.200.0		
B_{Ri} [mm]	Part No.	Installation set	B_{Ri} [mm]	Part No.	Installation set	B_{Ri} [mm]	Part No.	Installation set	B_{Ri} [mm]	Part No.	Installation set	B_{Ri} [mm]	Part No.	Installation set
.05	105	96.50.225	.05	105	96.50.225	.05	115	96.50.225	.05	85	*	.05	105	96.50.225
.06	120	96.50.250	.06	120	96.50.250	.06	130	96.50.250	.06	100	*	.06	120	96.50.250
.07	130	96.50.250	.07	130	96.50.250	.07	140	96.50.250	.07	110	96.50.225	.07	130	96.50.250
.10	155	96.50.275	.10	155	96.50.275	.10	165	96.50.275	.10	135	96.50.250	.10	155	96.50.275
.11	168	96.50.300	.11	168	96.50.300	.11	177	96.50.300	.11	148	96.50.275	.11	167	96.50.300
.12	180	96.50.300	.12	180	96.50.300	.12	190	96.50.300	.12	160	96.50.275	.12	180	96.50.300
.13	193	96.50.325	.13	193	96.50.325	.13	202	96.50.325	.13	173	96.50.300	.13	192	96.50.325
.15	205	96.50.325	.15	205	96.50.325	.15	215	96.50.325	.15	185	96.50.300	.15	205	96.50.325
.16	218	96.50.350	.16	218	96.50.350	.16	227	96.50.350	.16	198	96.50.325	.16	217	96.50.350
.17	230	96.50.350	.17	230	96.50.350	.17	240	96.50.350	.17	210	96.50.325	.17	230	96.50.350
.18	243	96.50.375	.18	243	96.50.375	.18	252	96.50.375	.18	223	96.50.350	.18	242	96.50.375
.20	255	96.50.375	.20	255	96.50.375	.20	265	96.50.375	.20	235	96.50.350	.20	255	96.50.375
.21	268	96.50.400	.21	268	96.50.400	.21	277	96.50.400	.21	248	96.50.375	.21	267	96.50.400
.22	280	96.50.400	.22	280	96.50.400	.22	290	96.50.400	.22	260	96.50.375	.22	280	96.50.400
.23	293	96.50.425	.23	293	96.50.425	.23	302	96.50.425	.23	273	96.50.400	.23	292	96.50.425
.25	305	96.50.425	.25	305	96.50.425	.25	315	96.50.425	.25	285	96.50.400	.25	305	96.50.425
.26	318	96.50.450	.26	318	96.50.450	.26	327	96.50.450	.26	298	96.50.425	.26	317	96.50.450
.27	330	96.50.450	.27	330	96.50.450	.27	340	96.50.450	.27	310	96.50.425	.27	330	96.50.450
.28	343	96.50.475	.28	343	96.50.475	.28	352	96.50.475	.28	323	96.50.450	.28	342	96.50.475
.30	355	96.50.475	.30	355	96.50.475	.30	365	96.50.475	.30	335	96.50.450	.30	355	96.50.475
.31	368	96.50.500	.31	368	96.50.500	.31	377	96.50.500	.31	348	96.50.475	.31	367	96.50.500
.32	380	96.50.500	.32	380	96.50.500	.32	390	96.50.500	.32	360	96.50.475	.32	380	96.50.500
.33	393	96.50.525	.33	393	96.50.525	.33	402	96.50.525	.33	373	96.50.500	.33	392	96.50.525
.35	405	96.50.525	.35	405	96.50.525	.35	415	96.50.525	.35	385	96.50.500	.35	405	96.50.525
.36	418	96.50.550	.36	418	96.50.550	.36	427	96.50.550	.36	398	96.50.525	.36	417	96.50.550
.37	430	96.50.550	.37	430	96.50.550	.37	440	96.50.550	.37	410	96.50.525	.37	430	96.50.550
.38	443	96.50.575	.38	443	96.50.575	.38	452	96.50.575	.38	423	96.50.550	.38	442	96.50.575
.40	455	96.50.575	.40	455	96.50.575	.40	465	96.50.575	.40	435	96.50.550	.40	455	96.50.575
.41	468	96.50.600	.41	468	96.50.600	.41	477	96.50.600	.41	448	96.50.575	.41	470	96.50.600
.42	480	96.50.600	.42	480	96.50.600	.42	490	96.50.600	.42	460	96.50.575	.42	480	96.50.600
.43	493	96.50.625	.43	493	96.50.625	.43	502	96.50.625	.43	473	96.50.600	.43	492	96.50.625
.45	505	96.50.625	.45	505	96.50.625	.45	515	96.50.625	.45	485	96.50.600	.45	505	96.50.625
.46	518	96.50.650	.46	518	96.50.650	.46	527	96.50.650	.46	498	96.50.625	.46	517	96.50.650
.47	530	96.50.650	.47	530	96.50.650	.47	540	96.50.650	.47	510	96.50.625	.47	530	96.50.650
.48	543	96.50.675	.48	543	96.50.675	.48	552	96.50.675	.48	523	96.50.650	.48	542	96.50.675
.50	555	96.50.675	.50	555	96.50.675	.50	565	96.50.675	.50	535	96.50.650	.50	555	96.50.675
.51	568	96.50.700	.51	568	96.50.700	.51	577	96.50.700	.51	548	96.50.675	.51	567	96.50.700
.52	580	96.50.700	.52	580	96.50.700	.52	590	96.50.700	.52	560	96.50.675	.52	580	96.50.700
.53	593	96.50.725	.53	593	96.50.725	.53	602	96.50.725	.53	573	96.50.700	.53	592	96.50.725
.55	605	96.50.725	.55	605	96.50.725	.55	615	96.50.725	.55	585	96.50.700	.55	605	96.50.725
.60	655	96.50.775	.60	655	96.50.775	.60	665	96.50.775	.60	635	96.50.750	.60	655	96.50.775

*upon request



Trough (Part No. 96.30 and 96.31)
with reinforced mounting angles for
very rugged and extreme applications

! The inner width of the guide through and the length of the C-Profile of the assembly kit can differ according to the bracket you choose. Please call us!



For the following
igus® Series

System E4

- 600/601/R608
- 640
- 1640/R1608



Fixed end module

Quick installation of the mounting brackets due to the prepared bores

▶ page 9.62

- B_a = Outer e-chain® width
- B_i = Inner e-chain® width
- h_a = e-chain® outer height
- H_{Ri} = Inner trough height
- H_{Ra} = Outer trough height
- B_{Ri} = Inner trough width ▶ depends on dim. B_a
- B_{Ra} = Outer trough width
- n_{Mon} = Number of installation sets (left/right)
- n_{Ri} = Number of trough sets (left/right)
- ! $H_{Ri} \geq 2 \cdot h_a$
- ! $B_{Ri} \geq B_a + 5$
- = Guide trough
- = Glide bar
- = Installation set
- = C-profile

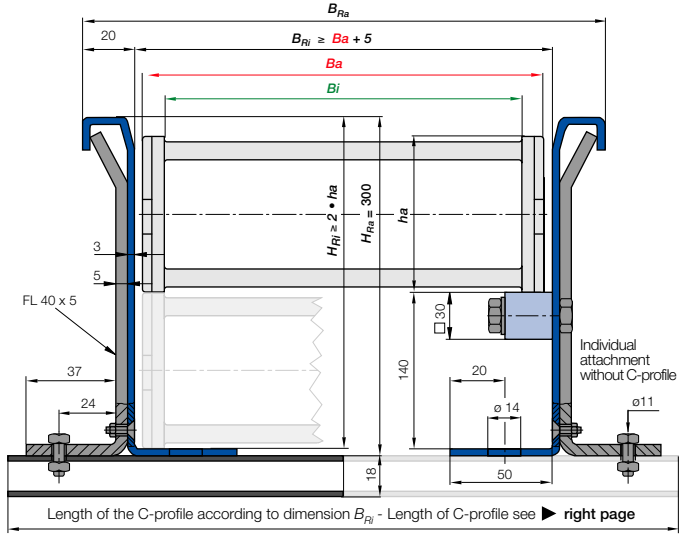

Steel Guide Trough components - Sets and single parts

Complete guide trough sets - description	Part No.	Weight	kg
Set of 2 trough side parts without glide bars, 2 m section	98.30	≈ 34,60 kg	
Set of 2 trough side parts with glide bars, 2 m section	98.31	≈ 39,00 kg	
1 Installation set with C-profile	98.50. <input type="text"/>		
1 Installation set without C-profile	98.50	≈ 1,16 kg	
Single parts - description			
1 glide bar, individual, each 2 m	93.01	≈ 1,68 kg	
1 glide bar, individual, each 2 m + 11 screw sets	93.20	≈ 2,22 kg	
11 screw sets for 2 m sections	93.21	≈ 0,54 kg	
1 Clamping bracket, individual	98.51	≈ 0,52 kg	
1 Countersunk-head screw M8 x 20, individual	92.05		
1 Hexagon nut M8, individual	92.04		
1 Hexagon-head screw M10 x 16, individual	92.55		
1 Glide nut M10, individual	92.56		
1 C-profile, individual	92.52. <input type="text"/>	≈ 0,90 kg/m	

Supplement Part No. with the indicated C-profile-length-index. Example: 98.50.

C-profile-length-index for your chosen trough inner width B_{Ri} ▶ right table

Trough side parts also available in stainless steel. Please add index "E" to the Part No. 98.30.E

Principle sketch: Number of installation sets which have to be installed

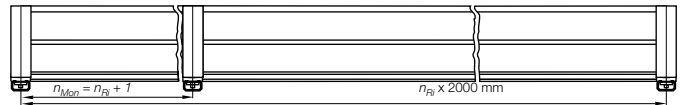

Calculation - travel
center mounted

Half travel length, rounded down to full 2 m sections = X m guide trough length without glide bars + X m guide trough length with glide bars + installation sets (number of trough pieces + 1)



Order example: Length of travel 30 m -
Center mounted for Series 600.20.200.0 with $B_{Ri} = 257$

Guide trough-set of 2 trough side parts, without glide bars:	
16 m Guide trough = 8 x 2 m sections (without glide bars)	Part No. 98.30
Guide trough-set of 2 trough side parts, with assembled glide bars:	
16 m Guide trough = 8 x 2 m sections (with glide bars)	Part No. 98.31
Installation sets complete (Guide trough-sets + 1)	
17 Installation sets (with C-profile)	Part No. 98.50. <input type="text" value="375"/>

Part No. Installation set: Steel Guide Trough with C-profile (in dependance of the width)

600/601/R608

600.20.200.0

B_{Rl} [mm]	Part No. Installation set
.20	257 98.50.375
.25	307 98.50.425
.30	357 98.50.475
.32	377 98.50.500
.35	407 98.50.525
.40	457 98.50.575
.45	507 98.50.625
.50	557 98.50.675
.55	607 98.50.725
.60	657 98.50.775

640

640.12.200.0

B_{Rl} [mm]	Part No. Installation set
.12	144 98.50.275
.13	157 98.50.275
.15	169 98.50.300
.16	182 98.50.300
.17	194 98.50.325
.18	207 98.50.325
.20	219 98.50.350
.21	232 98.50.350
.22	244 98.50.375
.23	257 98.50.375
.25	269 98.50.400
.26	282 98.50.400
.27	294 98.50.425
.28	307 98.50.425
.30	319 98.50.450
.31	332 98.50.450
.32	344 98.50.475
.33	357 98.50.475
.35	369 98.50.500
.36	382 98.50.500
.37	394 98.50.525
.38	407 98.50.525
.40	419 98.50.550
.41	432 98.50.550
.42	444 98.50.575
.43	457 98.50.575
.45	469 98.50.600
.46	482 98.50.600
.47	494 98.50.625
.48	507 98.50.625
.50	519 98.50.650
.51	532 98.50.650
.52	544 98.50.675
.53	557 98.50.675
.55	569 98.50.700
.60	619 98.50.750

1640/R1608

1640.05.200.0

B_{Rl} [mm]	Part No. Installation set
.05	89 *
.06	104 98.50.225
.07	114 98.50.250
.08	124 98.50.250
.10	139 98.50.275
.11	151 98.50.275
.12	164 98.50.300
.13	176 98.50.300
.15	189 98.50.325
.16	201 98.50.325
.17	214 98.50.350
.18	226 98.50.350
.20	239 98.50.375
.21	251 98.50.375
.22	264 98.50.400
.23	276 98.50.400
.25	289 98.50.425
.26	301 98.50.425
.27	314 98.50.450
.28	326 98.50.450
.30	339 98.50.475
.31	351 98.50.475
.32	364 98.50.500
.33	376 98.50.500
.35	389 98.50.525
.36	401 98.50.525
.37	414 98.50.550
.38	426 98.50.550
.40	439 98.50.575
.41	451 98.50.575
.42	464 98.50.600
.43	476 98.50.600
.45	489 98.50.625
.46	501 98.50.625
.47	514 98.50.650
.48	526 98.50.650
.50	539 98.50.675
.51	551 98.50.675
.52	564 98.50.700
.53	576 98.50.700
.55	589 98.50.725
.60	639 98.50.775

*upon request



For the following
igus® Series

System E4

- 800
- 840

Guide troughs with reinforced brackets for the largest igus® e-chains® Series 800 and 840. Especially designed for crane and off-shore applications



Fixed end module

Quick installation of the mounting brackets due to the prepared bores

▶ page 9.62

- B_a = Outer e-chain® width
- B_i = Inner e-chain® width
- h_a = e-chain® outer height
- H_{Ri} = Inner trough height
- H_{Ra} = Outer trough height
- B_{Ri} = Inner trough width ▶ depends on dim. B_a
- B_{Ra} = Outer trough width
- n_{Mon} = Number of installation sets (left/right)
- n_{Ri} = Number of trough sets (left/right)
- ▶ $H_{Ri} \geq 2 \cdot h_a$
- ▶ $B_{Ri} \geq B_a + 5$
- = Guide trough
- = Glide bar
- = Installation set
- = C-profile

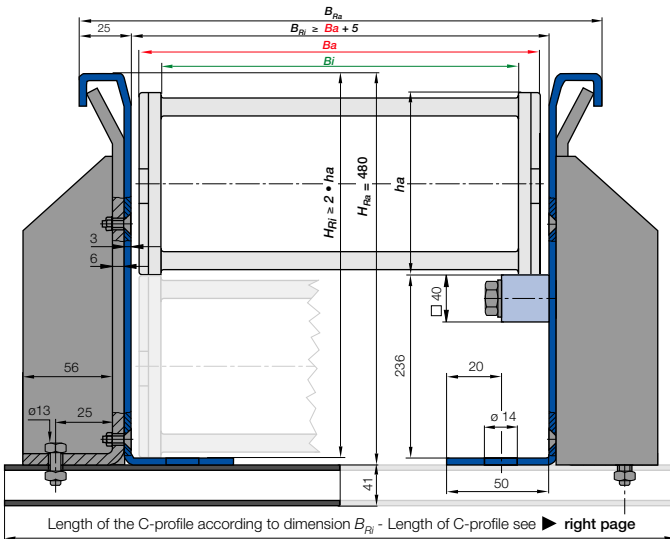

Steel Guide Trough components - Sets and single parts

Complete guide trough sets - description	Part No.	Weight	kg
Set of 2 trough side parts without glide bars, 2 m section	90.30	≈ 53,40 kg	
Set of 2 trough side parts with glide bars, 2 m section	90.31	≈ 59,40 kg	
1 Installation set with C-profile	90.50. <input type="text"/>		
1 Installation set without C-profile	90.50	≈ 0,41 kg	
Single parts - description			
1 glide bar, individual, each 2 m	90.01	≈ 3,00 kg	
1 glide bar, individual, each 2 m + 11 screw sets	90.20	≈ 3,50 kg	
11 screw sets for 2 m sections	90.21	≈ 0,50 kg	
1 Clamping bracket, individual	90.51	≈ 2,75 kg	
2 Countersunk-head screws M8 x 25, individual	92.53		
2 Hexagon nuts M8, individual	92.54		
1 Hexagon-head screw M12 x 30, individual	92.55		
1 Glide nut M12, individual	92.56		
1 C-profile, individual	92.52. <input type="text"/>	≈ 0,90 kg/m	

Supplement Part No. with the indicated C-profile-length-index. Example: 90.50.

C-profile-length-index for your chosen trough inner width B_{Ri} ▶ right table

Trough side parts also available in stainless steel. Please add index "E" to the Part No. 90.30.E

Principle sketch: Number of installation sets which have to be installed

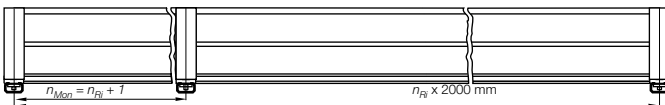

Calculation - travel
center mounted

Half travel length, rounded down to full 2 m sections = X m guide trough length without glide bars + X m guide trough length with glide bars + installation sets (number of trough pieces + 1)



Order example: Length of travel 30 m -
Center mounted for Series 800.20.325.0 with $B_{Ri} = 265$

Guide trough-set of 2 trough side parts, without glide bars:	
16 m Guide trough = 8 x 2 m sections (without glide bars)	Part No. 90.30
Guide trough-set of 2 trough side parts, with assembled glide bars:	
16 m Guide trough = 8 x 2 m sections (with glide bars)	Part No. 90.31
Installation sets complete (Guide trough-sets + 1)	
17 Installation sets (with C-profile)	Part No. 90.50. <input type="text" value="450"/>

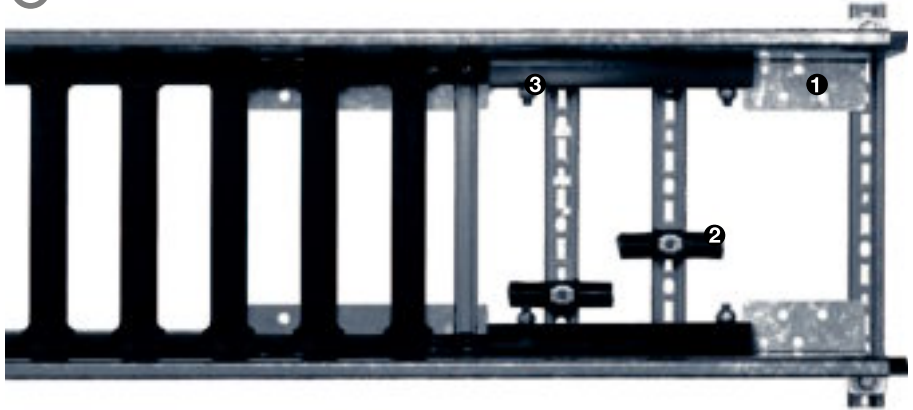

Fixed end module for steel guide troughs

Until now, the steel trough had to be modified on site to fit the mounting brackets at the stationary end of the e-chain®. That is now history. With its prefabricated boreholes, the 2.000 mm long kit can be used for middle-feed, end-feed and opposed installation.

- ① Fast fixation of mounting brackets thanks to prefabricated boreholes
- ② Fast installation of C-profile for strain relief
- ③ Fast bolting of glide bars
- Available immediately for Part No. 93.80.01, 94.80.01 and 96.80.01

Industries: Power plants, coal conveyors, mining, composting plants, raw material storage, gipsumplants, etc.



Part No.	For Steel guide troughs	For Series
90.80.01	90.30 / 90.31	800, 840
92.80.01*	92.30 / 92.31	2500, 255, E6.29, R6.29
93.80.01	93.30 / 93.31	3500, R68, E4.42/H4.42/R4.42, 390/390/R780, 3838/3938/R7838, E6.52, R6.52
94.80.01	94.30 / 94.31	E4.56/H4.56/R4.56, 400/410/R880, 4040/4140/R8840, 4040HD/R8840HD, 14040/14140/R18840, 14240/14340, E6.62
95.80.01*	95.30 / 95.31	2700
96.80.01	96.30 / 96.31	E4.80/H4.80/R4.80, 5050/5150/R9850, 5050HD/R9850HD, 15050/5150/R19850, E6.80, 14550/14650/19050
97.80.01*	97.30 / 97.31	E4.32/H4.32/R4.32, 280/290/R770, 2828/2928/R7728, E6.40, R6.40
98.80.01*	98.30 / 98.31	600/601/R608, 640, 1640/R1608
99.80.01*	99.30 / 99.31	E4.28/R4.28, 220/R760, E6.35

*available upon request - time of delivery 6 weeks after intake of order

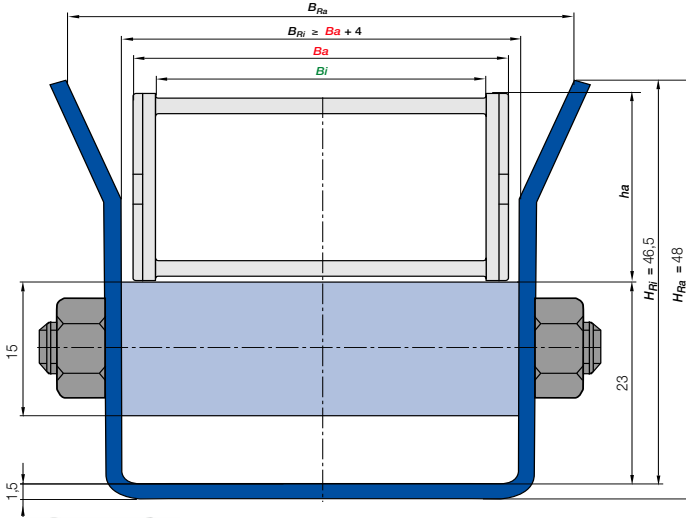

For the following
igus® Series

System E2

● 10

● B15

System zipper

● 15/R15



For Series 10, 15 and B15 are steel guide troughs for one side available. They have got a continuous glide bar for the transition from area with the glide bars to the area without glide bars. Available from stock are the guide troughs for the e-chains® with an outer width up to 60 mm. For the e-chains® with a width of more than 60 mm special solutions are on short call. For this trough sizes are no installation sets necessary as the guide troughs are made of a single U-profile. The solution for the trough joint is specific for every application.

B_{Ra} = Outer e-chain® width
B_{Ri} = Inner e-chain® width
ha = e-chain® outer height
H_{Ri} = Inner trough height
H_{Ra} = Outer trough height
B_{Ri} = Inner trough width
B_{Ra} = Outer trough width

For Series	Part No.	Dim. B _{Ra} [mm]	Dim. B _{Ri} [mm]	Weight
For Series 10.015/15.015/B15.015				
Trough without glide bar, 2-m section	91.10	40,5	30	1,50 kg/m
Trough with glide bar, 2-m section	91.11	40,5	30	2,10 kg/m
For Series 10.025/15.025/B15.025				
Trough without glide bar, 2-m section	91.20	50,5	40	1,65 kg/m
Trough with glide bar, 2-m section	91.21	50,5	40	2,35 kg/m
For Series 10.038/15.038/B15.038				
Trough without glide bar, 2-m section	91.30	62,5	52	1,80 kg/m
Trough with glide bar, 2-m section	91.31	62,5	52	2,70 kg/m
For Series 10.050/15.050/B15.050				
Trough without glide bar, 2-m section	91.40	72,5	62	1,90 kg/m
Trough with glide bar, 2-m section	91.41	72,5	62	3,15 kg/m
For Series 10.5/15.5/B15.5				
Trough without glide bar, 2-m section	91.50	89,5	79	2,15 kg/m
Trough with glide bar, 2-m section	91.51	89,5	79	4,30 kg/m
For Series 10.6/15.6/B15.6				
Trough without glide bar, 2-m section	91.60	106,5	96	≈ 2,40 kg/m
Trough with glide bar, 2-m section	91.61	106,5	96	≈ 4,60 kg/m
For Series 10.7/15.7/B15.7				
Trough without glide bar, 2-m section	91.70	126,5	116	≈ 2,80 kg/m
Trough with glide bar, 2-m section	91.71	126,5	116	≈ 5,20 kg/m

Trough material: St 1203 galvanized



Order example: Length of travel 30 m -
Center mounted for Series 10.038.100.0 with B_{Ri} = 52

Guide trough-channel without glide bars:

10 m Guide trough = 5 x 2 m sections (without glide bars) **Part No. 91.30**

Guide trough-channel with glide bars:

10 m Guide trough = 5 x 2 m sections (with glide bars) **Part No. 91.31**

Steel Guide Troughs
One-piece

Phone +49- (0) 22 03-96 49-800
Fax +49- (0) 22 03-96 49-222



The image features a blue background with industrial machinery. The top half shows a close-up of a metal frame with two vertical supports and a horizontal beam. The bottom half shows a robotic arm with multiple joints, positioned above a set of three parallel metal rails. The text 'Further troughs' is centered in the upper half.

Further troughs

Economically priced and simple guide options

igus® tubular trough and insert trough systems are simple and favorably priced options to safely guide e-chains®. Recommended for less demanding applications and applications with travel speeds below 2 m/s, as well as travel distances below 50 m. The igus® tubular trough is ideal for applications where quick cleaning and good visibility are required. The crucial advantage of the igus® insert trough is the low price and the very simple and fast installation.



Tubular trough system RS - lets light and dirt through

- Resistant to dirt - wear debris falls through
 - More translucent than sheet metal constructions
 - Easy and fast assembly
 - Low price
 - Easy and space saving delivery
 - iF-Design Award
- from page 9.66

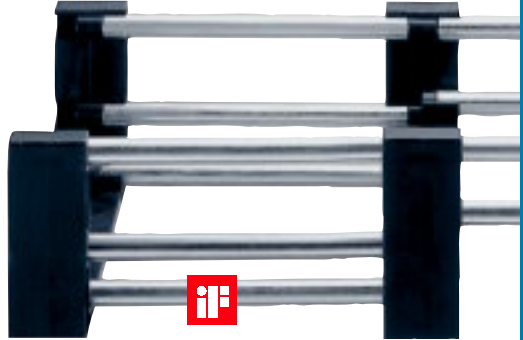

Snap-in trough system SP - simple and cost effective

- Smaller than conventional troughs
 - Easy and fast assembly
 - No sharp metal edges in the internal area because of covered connectors
 - Low price because of easy assembly
- from page 9.68



Especially for supporting the lower run - igus® Support tray



For support of the lower run - Support tray tool kit

- Complete system, ready to install
 - No more costly self-made designs
 - Easy installation onto your machine, on profiles or wall-mount brackets
- from page 9.70





The adjacent picture shows the transition from area without glide bar to area with glide bar in detail

Tubular trough system RS - low priced guide trough solution

The Tubular Trough System RS enables the setting up of a guide trough through simply connecting the polymer tubes and installation elements. This system is used practically everywhere in mechanical engineering where elegant design is important and where no great mechanical loads are present. The System RS is a good choice particularly where dirt, chips occur, because the waste products simply fall through the spaces and are hence not relevant as possible disturbance factors. The tubes are available in galvanized steel or polymer.

The assembly of the guide trough is very simple, because the individual elements are not screwed together but, instead, only pushed together and

clipped in. The difficult setting of the correct width is no longer necessary, since fitting spacers are delivered with the complete order. ● **The junction installation set** is required for junction of area without glide bar to area with glide bar ● **The fastening set (Part. No. 92.70 and Part. No. 92.71)** is used for fastening the fixed point of the above-mentioned e-chain® in the trough. It consists of 2 clamping parts which connect the end element (Material igumid G) **without** glide bar ❶ Installation set (Material igumid G) **with** glide bar ❷ Installation set of junction of area ❸ Tubular steel ø 12x1, (galvanized)

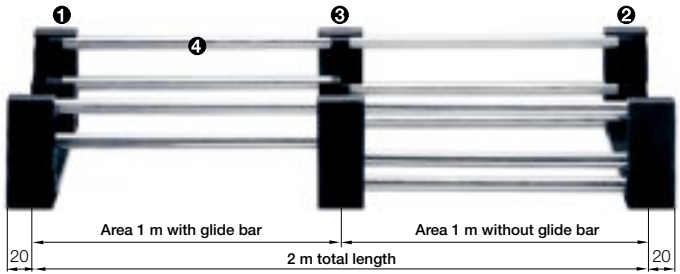

For the following igus® Series

- System E2
 - 2500
 - 255
 - 250 classic
- System E6
 - E6.29/R6.29*

XX	Bi	Ba	B _{Ra}	B _{Rl}
02*	25	41	81	45
03	38	54	94	58
05	57	73	113	77
07	77	93	133	97
09	89	105	145	109
10	103	119	159	123
12	125	141	181	145

XX = e-chain® width
* without spacer plate

Part No. 92.70 and Part No. 92.71

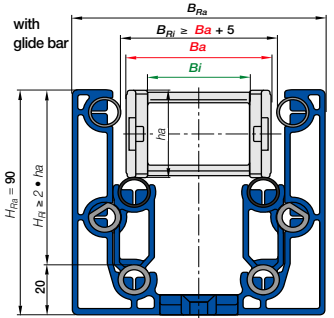
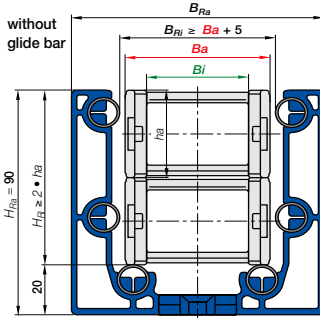

Tubular Trough Components	Part No.	Weight [kg]
Installation set without glide bars	92.70. XX	≈ 0,15
Installation set with glide bars	92.71. XX	≈ 0,12
Installation set junction	92.74. XX	
Fastening set	92.77.2	
Tubular steel, diameter 12 x 1 galvanized: (L = 985) for clearance Installation set 1 m	92.80	≈ 0,28

Supplement Part No. with the required width in the table. Example: 92.71. 10



Order Example: Inner width 57 mm. For 8 m trough the following parts are required:

- Area **with** glide bar: 4 x Installation set **Part No. 92.71.05** + tube: 4 x 4 piece **Part No. 92.80**
- Area **without** glide bar: 4 x Installation set **Part No. 92.70.05** + tube: 4 x 6 piece **Part No. 92.80**
- 1 x junction **Part No. 92.74.05**

Part No. 93.70 and Part No. 93.71

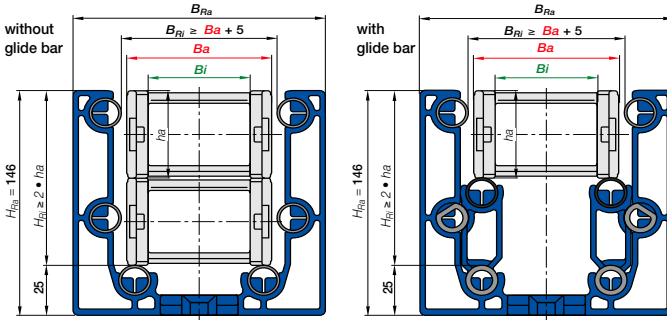

Tubular Trough Components	Part No.	Weight [kg]
Installation set without glide bars	93.70. XX	≈ 0,25
Installation set with glide bars	93.71. XX	≈ 0,20
Installation set junction	93.74. XX	
Tubular steel, diameter 12 x 1 galvanized; (L = 985) for clearance Installation set 1 m	93.80	≈ 0,50

Supplement Part No. with the required width in the table. Example: 93.71. **050**



Order Example: Inner width 50 mm. For 8 m trough the following parts are required:

Area with glide bar:	4 x Installation set Part No. 93.71.050 + tube: 4 x 4 piece Part No. 93.80
Area without glide bar:	4 x Installation set Part No. 93.70.050 + tube: 4 x 6 piece Part No. 93.80 1 x junction Part No. 93.74.050

For the following igus® Series

- System E2 Series
- 3500
- 350 classic
- System E6 Series
- E6.52* ● R6.52*

XX	Bi	Ba	B _{Ra}	B _{Rl}
050	50	70	130	75
075	75	95	155	100
100	100	120	180	125
115	115	135	195	140
125	125	145	205	150
150	150	170	230	175
175	175	195	255	200
200	200	220	280	225
225	225	245	305	250
250	250	270	330	275

XX = e-chain* width
* without spacer plate

For 1 m trough without glide bars
6 tubes 1 meter long are required.
For 1 m trough with glide bars 4
tubes 1 meter long are required.

Part No. 95.70 and Part No. 95.71

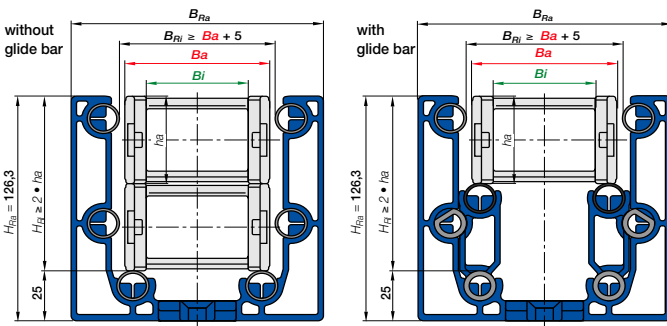

Tubular Trough Components	Part No.	Weight [kg]
Installation set without glide bars	95.70. XX	≈ 0,15
Installation set with glide bars	95.71. XX	≈ 0,12
Installation set junction	95.74. XX	
Fastening set	93.80	≈ 0,50

Tubular steel, diameter 12 x 1 galvanized; (L = 985) for clearance Installation set 1 m
Supplement Part No. with the required width in the table. Example: 95.71. **10**



Order Example: Inner width 50 mm. For 8 m trough the following parts are required:

Area with glide bar:	4 x Installation set Part No. 95.71.05 + tube: 4 x 4 piece Part No. 93.80
Area without glide bar:	4 x Installation set Part No. 95.70.05 + tube: 4 x 6 piece Part No. 93.80 1 x junction Part No. 95.74.05

For the following igus® Series

- System E2 Series
- 2700
- 27 classic

XX	Bi	Ba	B _{Ra}	B _{Rl}
05	50	66	124	71
06*	65	81	139	86
07	75	91	149	96
09*	90	106	164	111
10	100	116	174	121
12	125	141	199	146
15	150	166	224	171
17	175	194	252	199
20	200	219	277	224

XX = e-chain* width
* upon request

For 1 m trough without glide bars
6 tubes 1 meter long are required.
For 1 m trough with glide bars 4
tubes 1 meter long are required.





The spacer plate makes the trough installation easier because it is no longer necessary to set the trough width

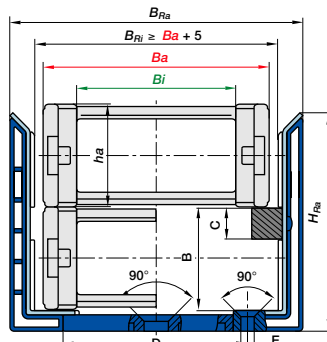

For the following
igus® Series

System E2

- 10
- B15/B15i
- zipper
- 15

Part No. 91.930

Snap-In Trough Components

Part No.	Weight [kg/m]
Trough set without glide bars, 2 glide strips of 1 m	91.930 ≈ 1,50
Trough set with glide bars, 2 glide strips of 1 m	91.931 ≈ 1,90
Glide bar set, 2 glide bars, 1 m section	91.920
Screw set	91.921
Installation set with spacer plate	91.950. XX ≈ 0,05
Installation set without spacer plate	91.950 ≈ 0,03

Supplement Part No. with the required width in the table. Example: 91.950. **05**

XX	H _{Ra}	B	C	B _{Ri}	D	ø E	B _{Ra}
015	55,5	23	12	29,6	21	4,2	46
025	55,5	23	12	39,6	31	4,2	56
038	55,5	23	12	51,6	43	4,2	68
050	55,5	23	12	63,6	55	4,2	80
05	55,5	23	12	79,6	71	4,2	96
06	55,5	23	12	96,6	88	4,2	113
07	55,5	23	12	116,6	108	4,2	133



For the following
igus® Series

System E2

- 2500
- 250 classic

System E6

- E6.29 ● R6.29

(without spacer plate)

Part No. 92.930

Snap-In Trough Components

Part No.	Weight [kg/m]
Trough set without glide bars, 2 glide strips of 2 m	92.930 ≈ 5,50
Trough set with glide bars, 2 glide strips of 2 m	92.931 ≈ 6,50
Glide bar set, 2 glide bars, 2 m section	92.920
Screw set	92.921
Installation set with spacer plate	92.950. XX ≈ 0,10
Installation set without spacer plate	92.950 ≈ 0,08

Supplement Part No. with the required width in the table. Example: 92.950. **05**

XX	H _{Ra}	B	C	B _{Ri}	D	ø E	B _{Ra}
02*	76,6	35	15	43	14	6,6	67
03	76,6	35	15	56	27	6,6	80
05	76,6	35	15	75	46	6,6	99
07	76,6	35	15	95	66	6,6	119
09	76,6	35	15	107	78	6,6	131
10	76,6	35	15	121	92	6,6	145
12	76,6	35	15	143	114	6,6	167

XX = e-chain* width

* without spacer plate

Order Example - for 20 m trough Part. No. 93.930
the following parts are required:

10 m Part No. 93.930, Trough set without glide bars (5 x 2 m)

10 m Part No. 93.931, Trough set with glide bars (5 x 2 m)

Part No. 93.950. 050, Installation set

Ba = Outer e-chain* width
Bi = Inner e-chain* width
ha = e-chain* outer height
H_{Ri} = Inner trough height
H_{Ra} = Outer trough height
B_{Ri} = Inner trough width ►
depends on dim. *Ba*
B_{Ra} = Outer trough width

Part No. 93.930 Snap-In Trough Components	Part No.	Weight Trough [kg/m]
Trough set without glide bars, 2 glide strips of 2 m	93.930	≈ 9,00
Trough set with glide bars, 2 glide strips of 2 m	93.931	≈ 10,00
Glide bar set, 2 glide bars, 2 m section	93.920	
Screw set	93.921	
Installation set with spacer plate	93.950. XX	≈ 0,20
Installation set without spacer plate	93.950	≈ 0,16

Supplement Part No. with the required width in the table. Example: 93.950. 050

XX	<i>H_{Ra}</i>	B	C	<i>B_{Ri}</i>	D	ø E	<i>B_{Ra}</i>
050	138,6	64	15	74	40	6,6	102
075	138,6	64	15	99	65	6,6	127
100	138,6	64	15	124	90	6,6	152
115	138,6	64	15	139	105	6,6	167
125	138,6	64	15	149	115	6,6	177
150	138,6	64	15	174	140	6,6	202
175	138,6	64	15	199	165	6,6	227
200	138,6	64	15	224	190	6,6	252
225	138,6	64	15	249	215	6,6	277
250	138,6	64	15	274	240	6,6	302

For the following igus® Series

- System E2
 - 3500
 - 350 classic
 - System E6
 - E6.52 ● R6.52
- (without spacer plate)

Phone +49- (0) 22 03-96 49-800
Fax +49- (0) 22 03-96 49-222

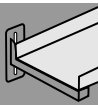

Art. Nr. 95.930 Snap-In Trough Components	Part No.	Weight Trough [kg/m]
Trough set without glide bars, 2 glide strips of 2 m	95.930	≈ 7,10
Trough set with glide bars, 2 glide strips of 2 m	95.931	≈ 8,10
Glide bar set, 2 glide bars, 2 m section	95.920	
Screw set	95.921	
Installation set with spacer plate	95.950. XX	≈ 0,11
Installation set without spacer plate	95.950	≈ 0,13

Supplement Part No. with the required width in the table. Example: 95.950. 05

XX	<i>H_{Ra}</i>	B	C	<i>B_{Ri}</i>	D	ø E	<i>B_{Ra}</i>
05	106,6	50	15	70	40	6,6	94
06*	106,6	50	15	85	55	6,6	109
07	106,6	50	15	95	65	6,6	119
09*	106,6	50	15	110	80	6,6	134
10	106,6	50	15	120	90	6,6	144
12	106,6	50	15	145	115	6,6	169
15	106,6	50	15	170	140	6,6	194
17	106,6	50	15	198	168	6,6	222
20	106,6	50	15	223	193	6,6	247

For the following igus® Series

- System E2
- 2700
- 27 classic

XX = e-chain* width
* without spacer plate



Support Tray

Support tray | For support of the lower run



For support of the lower run - Support tray tool kit

Simple one-piece support trays for the lower e-chain®, according with your requirements and specification. Your width, height and color - we supply the fitting e-chain®, together with the support tray system. Ready to install onto your machine or application. Save on procurement and design time.

- Complete system, ready to install
- No more costly self-made designs
- Easy installation onto your machine, on profiles or wall-mount brackets

igus® support tray - in 2 types
and 4 options available

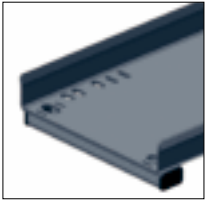

Option 01 -
with connection-rail

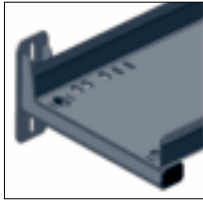

Option 02 -
with bracket

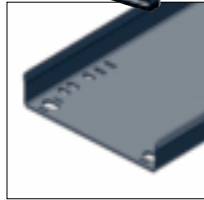

Option 03 -
without rail (upon request)

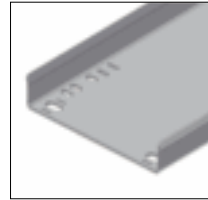

Option 04 -
customized (upon request)

For many widths available from stock,
with many mounting possibilities



Delivery time: 3-10 days





For the following
igus® Series

E2/000
● 2400/2450/2480/2500
● 2600/2650/2680/2700
E4.1
● E4.21 (210)
● E4.28/R4.28
● E4.32/H4.32/R4.32
E4/00
● 220/R760
● 280/290/R770
E4/4
● 2828/2928/R7728
E6
● E6.29/R6.29
● E6.35
● E6.40/R6.40

- ① Support tray type 01 - Standard-length from stock 1 m and 2 m
- ② All connection rails 975 mm
- ③ Bracket for easy mounting on your application

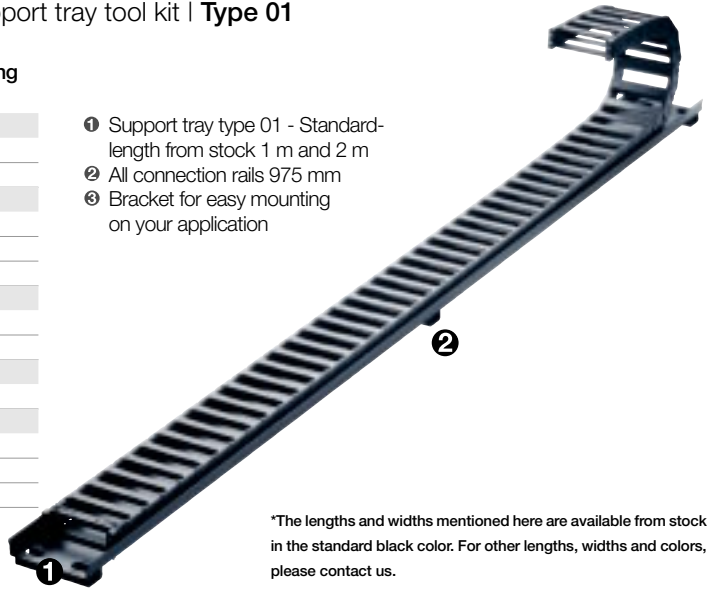

*The lengths and widths mentioned here are available from stock in the standard black color. For other lengths, widths and colors, please contact us.

Product Range*

System	Suitable for the following series ▼	Widths-index	B_{Ra} [mm]	B_{Rl} [mm]	Part No. Support-tray, single	Part No. Support-tray with bracket	Part No. single bracket
E2/000	2400/2450/2480/2500	.05	89	80	S9.010.05. [XXXX] .0	S9.011.05. [XXXX] .0	907.724.05.0
		.07	114	105	S9.010.07. [XXXX] .0	S9.011.07. [XXXX] .0	907.724.07.0
		.10	139	130	S9.010.10. [XXXX] .0	S9.011.10. [XXXX] .0	907.724.10.0
E2/000	2600/2650/2680/2700	.05	89	80	S9.010.05. [XXXX] .0	S9.011.05. [XXXX] .0	907.724.05.0
		.07	114	105	S9.010.07. [XXXX] .0	S9.011.07. [XXXX] .0	907.724.07.0
		.10	139	130	S9.010.10. [XXXX] .0	S9.011.10. [XXXX] .0	907.724.10.0
E4.1	E4.32/H4.32/R4.32	.07	114	105	S9.010.07. [XXXX] .0	S9.011.07. [XXXX] .0	907.724.07.0
E4/4	2828/2928/R7728	.10	139	130	S9.010.10. [XXXX] .0	S9.011.10. [XXXX] .0	907.724.10.0
E4/00	280/290/R770	.15	185	175	S9.010.15. [XXXX] .0	S9.011.15. [XXXX] .0	907.724.15.0
E4.1	E4.21	.050	89	80	S9.010.05. [XXXX] .0	S9.011.05. [XXXX] .0	907.724.05.0
		.070	114	105	S9.010.07. [XXXX] .0	S9.011.07. [XXXX] .0	907.724.07.0
		.100	139	130	S9.010.10. [XXXX] .0	S9.011.10. [XXXX] .0	907.724.10.0
E6	E6.29/R6.29	.050	89	80	S9.010.05. [XXXX] .0	S9.011.05. [XXXX] .0	907.724.05.0
		.070	114	105	S9.010.07. [XXXX] .0	S9.011.07. [XXXX] .0	907.724.07.0
		.100	139	130	S9.010.10. [XXXX] .0	S9.011.10. [XXXX] .0	907.724.10.0
E6	E6.35	.050	89	80	S9.010.05. [XXXX] .0	S9.011.05. [XXXX] .0	907.724.05.0
		.070	114	105	S9.010.07. [XXXX] .0	S9.011.07. [XXXX] .0	907.724.07.0
		.100	139	130	S9.010.10. [XXXX] .0	S9.011.10. [XXXX] .0	907.724.10.0
E4.1	E4.28/R4.28	.050	89	80	S9.010.05. [XXXX] .0	S9.011.05. [XXXX] .0	907.724.05.0
		.070	114	105	S9.010.07. [XXXX] .0	S9.011.07. [XXXX] .0	907.724.07.0
		.100	139	130	S9.010.10. [XXXX] .0	S9.011.10. [XXXX] .0	907.724.10.0
E4/00	220/R760	.050	89	80	S9.010.05. [XXXX] .0	S9.011.05. [XXXX] .0	907.724.05.0
		.070	114	105	S9.010.07. [XXXX] .0	S9.011.07. [XXXX] .0	907.724.07.0
		.100	139	130	S9.010.10. [XXXX] .0	S9.011.10. [XXXX] .0	907.724.10.0
E6	E6.40/R6.40	.050	89	80	S9.010.05. [XXXX] .0	S9.011.05. [XXXX] .0	907.724.05.0
		.070	114	105	S9.010.07. [XXXX] .0	S9.011.07. [XXXX] .0	907.724.07.0
		.100	139	130	S9.010.10. [XXXX] .0	S9.011.10. [XXXX] .0	907.724.10.0

Please replace [XXXX] by the standard lengths 1000 or 2000 mm available from stock!

Accessories - optional bracket

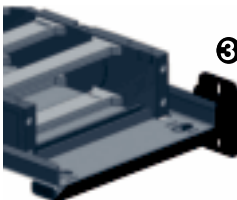

Bracket for easy mounting on your application (see table above for Part No.)

Mounting holes of the trough system

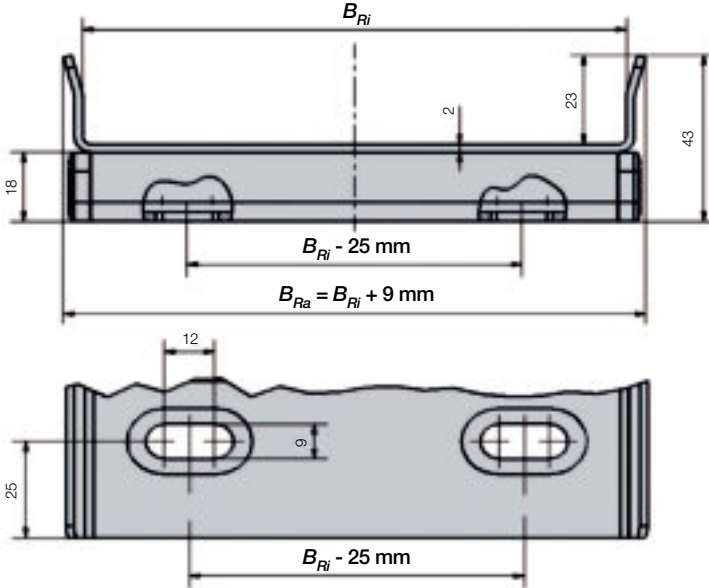

Standard lengths from stock 1 m and 2 m - All connection rails 975 mm

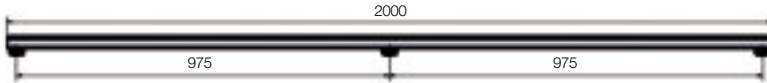

S9. 010. 07. 1000. 0



Part No. structure
1000 mm

- Color, powdered black
- Length 1000 mm
- e-chain®- width without bracket
- Support tray

S9. 011. 15. 2000. 0



Part No. structure
2000 mm

- Color, powdered black
- Length 2000 mm
- e-chain®- width with bracket
- Support tray

Bracket - Type 01

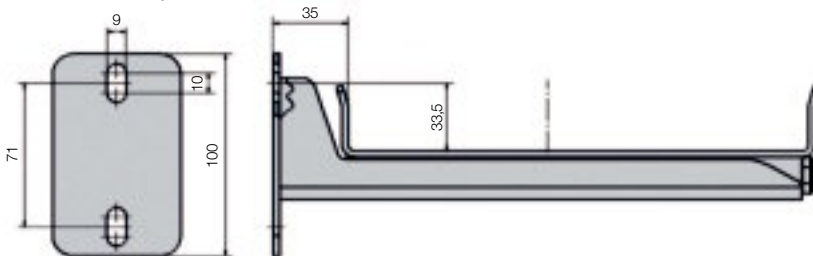



For the following
igus® Series

- E2/000
 - 3400/3450/3480/3500
- E4.1
 - E4.42/H4.42/R4.42
 - E4.56/H4.56/R4.56
 - E4.80/H4.80/R4.80
- E4/00
 - 380/390/R780
 - 400/410/R880
- E4/4
 - 3838/3938/R7838
 - 4040/4140/R8840
 - 5050/5150/R9850
- E4/light
 - 14040/14140/R18840
 - 14240/14340
 - 15050/15150/R19850
 - 15250/15350
- E4/00
 - E6.52/R6.52
 - E6.62
 - E6.80

- ① Support tray type 02 - Standard-length from stock 1 m and 2 m
- ② All connection rails 975 mm
- ③ Bracket for easy mounting on your application

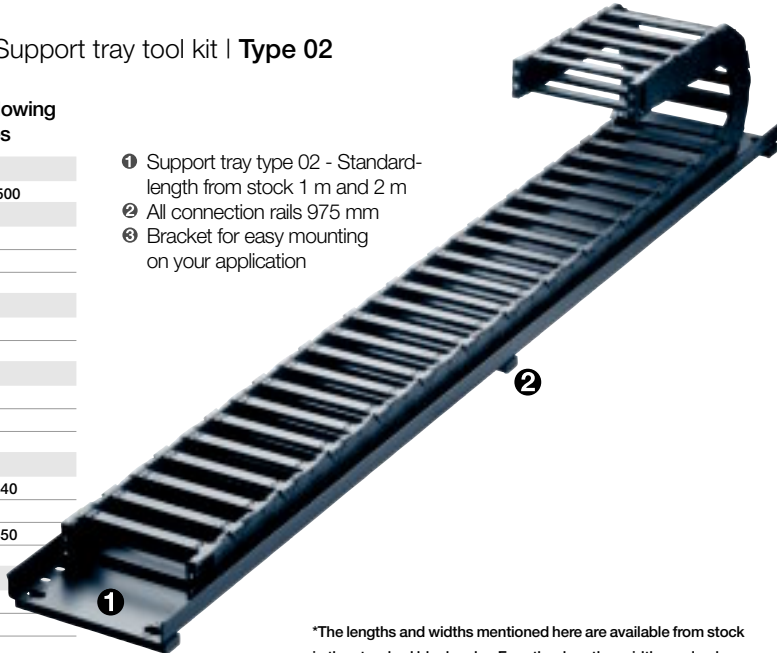

*The lengths and widths mentioned here are available from stock in the standard black color. For other lengths, widths and colors, please contact us.

Product Range*

System	Suitable for the following series ▼	Widths-index	B_{Ra} [mm]	B_{Ri} [mm]	Part No. Support-tray, single	Part No. Support-tray with bracket	Part No. single bracket
E4.1	E4.42/H4.42/R4.42	.10	167	156	S9.020.10, [XXXX].0	S9.021.10, [XXXX].0	907.759.10.0
E4.1	E4.56/H4.56/R4.56	.15	217	206	S9.020.15, [XXXX].0	S9.021.15, [XXXX].0	907.759.15.0
E4.1	E4.80/H4.80/R4.80	.20	267	256	S9.020.20, [XXXX].0	S9.021.20, [XXXX].0	907.759.20.0
E4/00	380/390/R780	.25	317	306	S9.020.25, [XXXX].0	S9.021.25, [XXXX].0	907.759.25.0
E4/00	400/410/R880						
E4/4	3838/3938/R7838						
E4/4	4040/4140/R8840						
E4/4	5050/5150/R9850						
E4/light	14040/14140/R18840						
E4/light	14240/14340						
E4/light	15050/15150/R19850						
E4	15250/15350						
E6	E6.62						
E6	E6.80						
E2/000	3400/3450/3480/3500	.100	167	156	S9.020.10, [XXXX].0	S9.021.10, [XXXX].0	907.759.10
E6	E6.52/R6.52	.150	217	206	S9.020.15, [XXXX].0	S9.021.15, [XXXX].0	907.759.15
		.200	267	256	S9.020.20, [XXXX].0	S9.021.20, [XXXX].0	907.759.20
		.250	317	306	S9.020.25, [XXXX].0	S9.021.25, [XXXX].0	907.759.25

Please replace [XXXX] by the standard lengths 1000 or 2000 mm available from stock!

Accessories - optional bracket

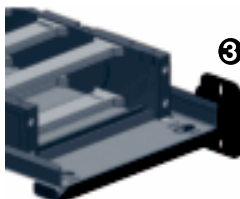

Bracket for easy mounting on your application (see table above for Part No.)

Internet: www.igus.eu
E-mail: info@igus.de

Mounting holes of the trough system

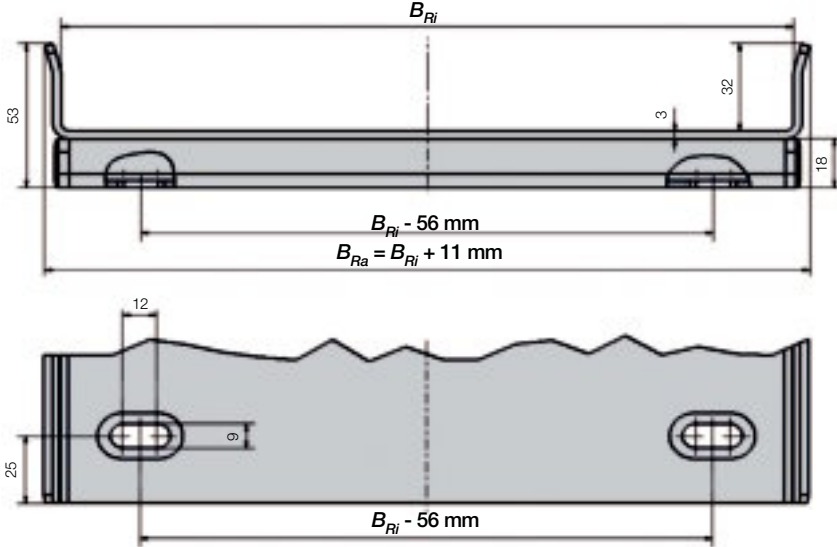

Standard lengths from stock 1 m and 2 m - All connection rails 975 mm

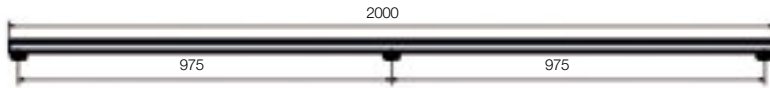

S9. 020. 20. 1000. 0

Part No. structure 1000 mm



- Color, powdered black
- Length 1000 mm
- e-chain"- width without bracket
- Support tray

S9. 021. 20. 2000. 0

Part No. structure 2000 mm



- Color, powdered black
- Length 2000 mm
- e-chain"- width with bracket
- Support tray

Bracket - Type 02

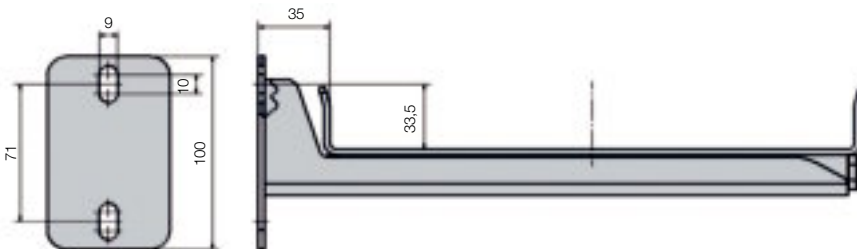

Special Solutions for Long Travels



System P4 | rol e-chain® | Reduce 57% energy consumption - for very long travels, high speeds, quiet



Product	Page
System P4	
System P4 Safe, maintenance-free energy supply system on long travels up to 60m and more for outdoor cranes or conveyor systems. low-noise operation, high service life	9.78

rol e-chain® | Rolling instead of gliding



Product	Page
rol e-chain®	
Major reduction in drive power to less than 25 % for moving the e-chain®	
Travels up to 60m, speeds up to 6m/s	9.86

System autoglide | Long travels without guide troughs



Product	Page
autoglide	
Self-guiding e-chainsystems® - No Guide Troughs required!	
Travels up to 50m, speeds up to 15 m/s	9.90

guidelok horizontal | Upper run guide for long travels



Product	Page
guidelok horizontal	
Chips cannot get stuck between upper and lower run -	
Enormous increase of „self supporting“ length of e-chains®	9.96

guidelok slimline "F" | For safe vertical guidance **NEW** in this catalog



Product	Page
guidelok slimline "F"	
No swinging of the e-chain®, high reliability through lever mechanism and guiding rails	
No bouncing of e-chains® in vertical applications with horizontal dynamics	9.98

lbt flizz® | Enclosed plastic trough



Product	Page
lbt flizz®	
Modular guide trough construction kit	
Travels up to 20m, speeds up to 8m/s	9.100

micro flizz® | Small e-chains® in aluminum profile



Product	Page
micro flizz®	
IE compact system for a secure guidance of power, data and air	
Maintenance-free alternative for busbar	9.104

levichain | Magnetic e-chainsystem® - it floats"



Product	Page
levichain	
Long travel possible without laying the e-chain® systems on top of each other. Almost no abrasion and very low wear due to low-abrasion e-chain® links as well as almost contactless movement of the e-chain®	9.112



System P4

A close-up photograph of a dark grey mechanical assembly, likely a component of a larger system. The assembly features a central white vertical component, possibly a sensor or actuator, surrounded by various circular and rectangular ports and structures. The background is a solid blue color.

System P4 | rol e-chain® | For very long travels, speed (up to 10 m/s)



Standard rol e-chain® has been used in over 1000 installations worldwide. Some industries -cranes, for example - have ever-increasing demands for length of travel, fill weight and speed. **Systems of this type should be designed by our system design engineers. We will be more than willing to submit an offer to you. Please contact us about this.**

- Identical pitch of the chain link with or without roller
- Smooth, low noise operation through identical pitch length for links with and without rollers
- Integrated "captive" roller in the side part
- Long travels (up to 800 m), high additional loads (up to 30 kg/m)
- For very long travels and high speeds >10 m/s travel speed
- autoglide crossbars provide for a safe guiding in very long travels
- 4 different inner heights: (32, 42, 56, 80 mm) available
- Large modular tool box system with interior separations of the System E4

Typical industries and applications

- Cranes ● Warehousing ● Equipment manufacturing ● Gantry robots ● Material handling

Find a video online ► www.igus.de/P4_Film
 Application video ► www.igus.de/P4cranes



Offset operation of upper and lower run, resulting in continuous roll-through surface

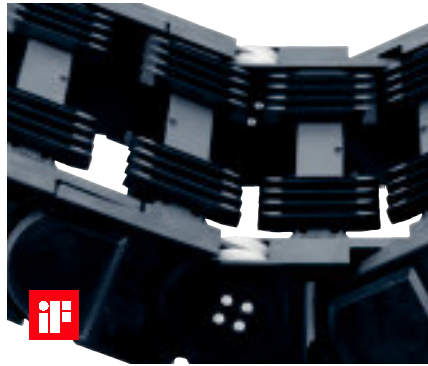

System P4 - Very quiet operation through identical pitch of all chain links. autoglide crossbars offer a safe guidance in very long travels

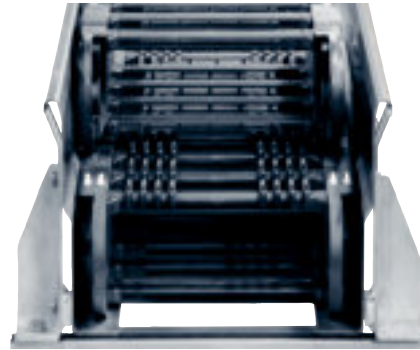

Guide trough system linked with the autoglide crossbars ensures the offset operation of the upper and lower run - safe at high speeds

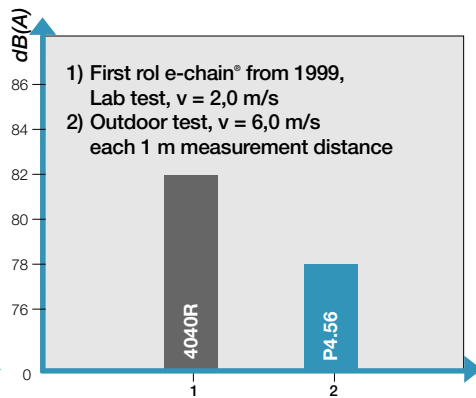
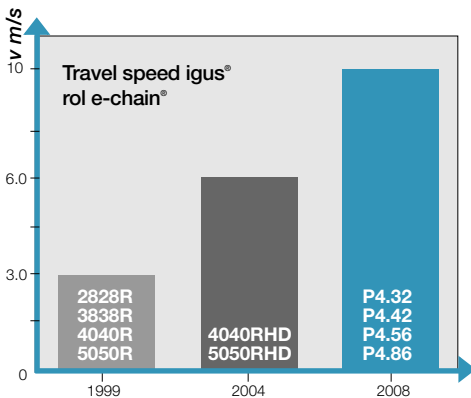

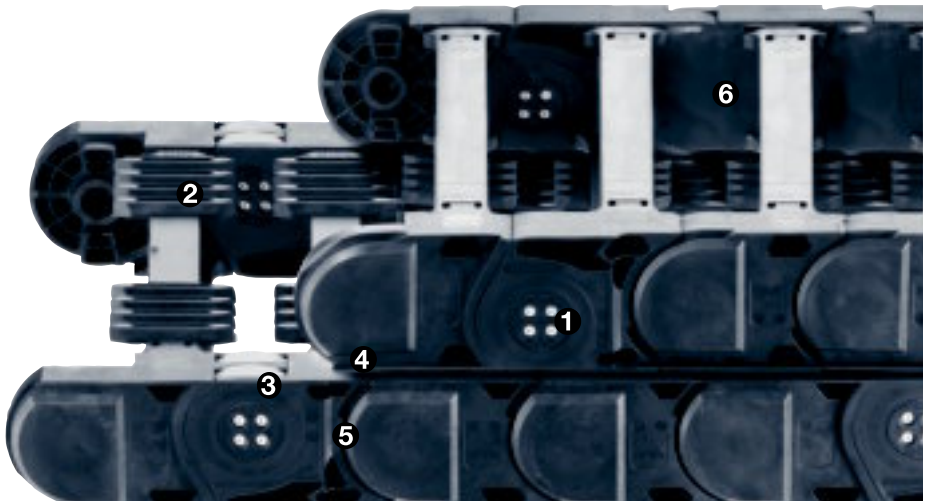

Safe, low-noise, abrasion-resistant energy supply system on long travels - igus® system P4

With the low-maintenance igus® System P4, a secure energy supply system can be implemented on long travels up to 800 m for cranes or conveyor systems. The upper run and lower run roll staggered on each other. Thus the tribo-optimized plastic rollers don't overrun, but roll on a continuous, wide roll-through surface. The P4 e-chain® is safely guided by the comb-shaped autoglide crossbars and the special trough system. **Ideal for applications with high travel speeds (up to 10 m/s) and large fill weights (up to 30 kg/m)**

- ❶ Low maintenance rol e-chainsystem* from tribooptimized plastic rollers
- ❷ Combstile autoglide cross bars
- ❸ Exceptionally quiet through special roller and link design
- ❹ Offset motion of upper and lower run
- ❺ Same pitch for roller- / chain links
- ❻ 4 different inner heights: 32, mm, 56 and 80 mm available
- ❼ Extension link solution for still higher fill weights with 56 and 80 mm inner height available
- ❽ Robust steel mounting brackets available
- ❾ Special P4 guide trough system available



- Extension link for heavy fill weights
- 2 inner heights available (56, 80 mm)
- 50% higher fill weight possible
- Maximum rigidity
- Divides cross section into reasonable compartments (electric/hydraulic)



- Tribo-optimized plastic rollers for all P4 systems
- Wear optimized
- Long cycle life
- Improved rolling
- Lower noise and vibration
- Same pitch for roller links / chain links

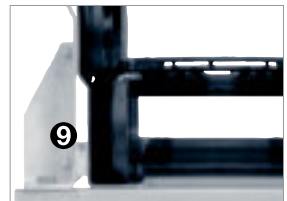

- Guide trough system
- Special geometry in combination with autoglide cross bars allows for offset upper and lower run
- Strong installation kits for long cycle life
- Stainless trough segments resist corrosion and sea water

Energy efficient polymer e-chains® and cables reduce consumption by up to 57%

With the right materials and clever design, the energy consumption can be drastically reduced, as now proven by current tests and sample calculations in the e-chain® and cable laboratory at igus®. igus® e-chains® and chainflex® cables reduce the required drive power and extend the application's service life.

Better cables, stronger and rolling e-chains®	System P4 -57%	
Rolling instead of gliding	rol e-chain® -37%	
Stronger e-chains®	System E4.1 -17%	
Optimized cables	chainflex® -17%	
Gliding application	Standard 100%	

System P4

+

=

-57%
less energy consumption

Sample calculations online ► www.igus.eu/energyefficiency



Successful application with P4.56 on a new RMG crane. 130 m travel length at 150 m/min speed. Equipped with igus® chainflex® motor-, control- and fiber optic cables

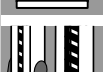
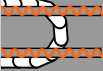
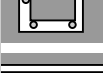
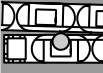
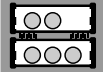

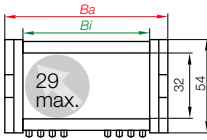
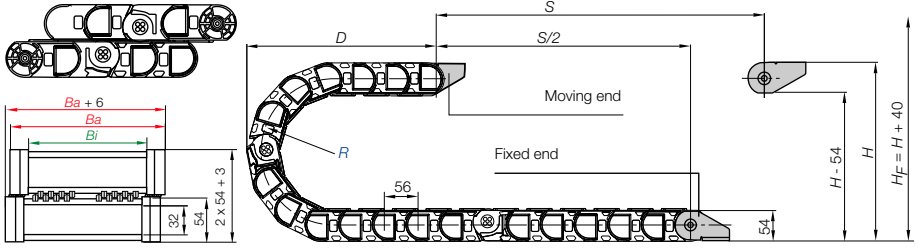

Part No. structure

P4.32.20.150.0.



Series P4.32 - rol e-chain® with combstipe autoglide cross bars

Part No.	Bi	Ba	R	Bending Radii						Weight [kg/m]	
P4.32.10.	.0	100	132	075	100	125	150	200	250	300	≈ 3,27
P4.32.15.	.0	150	182	075	100	125	150	200	250	300	≈ 3,83
P4.32.20.	.0	200	232	075	100	125	150	200	250	300	≈ 4,50

The bending radii 075 | 100 | 125 | 200 | 250 | 300 are available upon request.

Delivery time: approx. 6-8 weeks after receipt of order!

Supplement Part No. with required radius. Example: P4.32.15.150,0

0 = standard color, other colors ▶ page 1.39

Pitch = 56 mm/link Links/mm= 18 (1008 mm) Chain length = $S/2 + K$

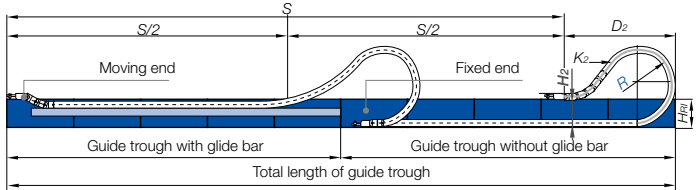

R	075°	100°	125°	150	200°	250°	300°
H	209	259	309	359	459	559	659
D	160	185	210	235	285	335	385
K	350	430	505	585	745	900	1055
H ₂	*	*	125	125	125	125	125
D ₂	*	*	*	*	*	*	*
K ₂	*	*	*	*	*	*	*

*upon request

Technical Data



Details of material properties

▶ page 1.38

Long travels	from 10 m up to max. 600 m
Speed max. rolling / acceleration max. rolling	max. 10 [m/s] / max. 50 [m/s ²]
Fill weight	max. 7,0 [kg/m]
Material - permitted temperature °C	igumid G / -40° up to +120° C
Flammability class, igumid G	VDE 0304 IIC UL94 HB

Additional Features



Interior separation
available - Series E4.32
▶ from page 7.42



Robust steel mounting
brackets available
▶ upon request



Special P4 guide
trough system available
▶ upon request

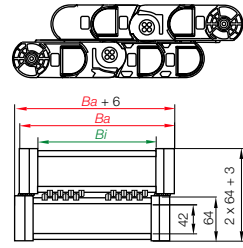
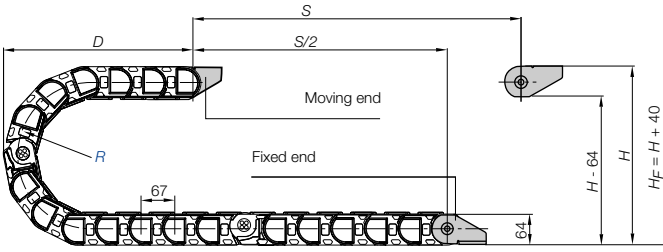

Series P4.42 - rol e-chain® with combstile autoglide cross bars

Part No.	Bi	Ba	R	Bending Radii	Weight [kg/m]
P4.42.10.□.0	100	154	100	125 150 200 250 300 350	≈ 4,49
P4.42.15.□.0	150	204	100	125 150 200 250 300 350	≈ 4,99
P4.42.20.□.0	200	254	100	125 150 200 250 300 350	≈ 5,55

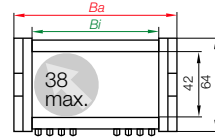

The bending radii **100** **125** **150** **200** **300** **350** are available upon request.

Delivery time: approx. 6-8 weeks after receipt of order!

Supplement Part No. with required radius. Example: P4.42.15. **250** .0

0 = standard color, other colors ▶ page 1.39

Part No. structure

P4.42.15.250.0.



Pitch = 67 mm/link **Links/m = 15 (1005 mm)** **Chain length = $S/2 + K$**

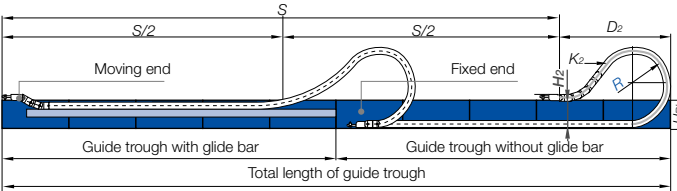

R	100*	125*	150*	200*	250	300*	350*
H	268	318	368	468	568	668	768
D	201	226	251	301	351	401	451
K	450	530	610	765	920	1080	1235
H ₂	140	140	140	140	140	140	140
D ₂	*	*	*	*	*	*	*
K ₂	*	*	*	*	*	*	*

*upon request

- S = Length of travel
- R = Bending radius
- H = Nominal clearance height
- H_F = Required clearance height
- H_{RI} = Trough inner height
- D = Overlength e-chain® radius in final position
- K = $\pi \cdot R + \text{"safety"}$
- D₂ = Overlength - long travels, gliding
- K₂ = "Further add-on"
- H₂ = "Mounting height"

*if the mounting bracket location is set lower

Long travels	from 10 m up to max. 800 m
Speed max. rolling / acceleration max. rolling	max. 10 [m/s] / max. 50 [m/s]
Fill weight	max. 15,0 [kg/m]
Material - permitted temperature °C	igumid G / -40° up to +120° C
Flammability class, igumid G	VDE 0304 IIC UL94 HB

Technical Data



Details of material properties

▶ page 1.38



Interior separation available - Series E4.42
▶ from page 7.60



Robust steel mounting brackets available
▶ upon request



Special P4 guide trough system available
▶ upon request

Additional Features

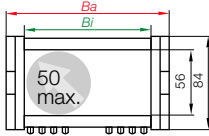
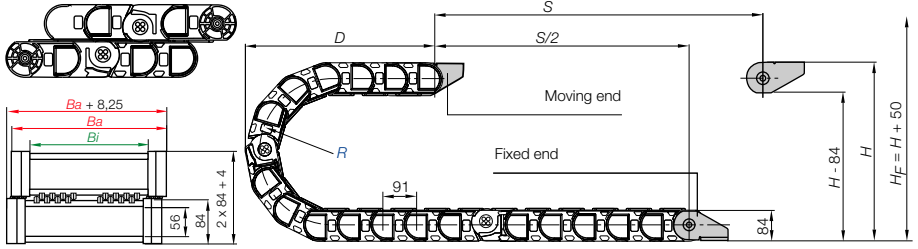

Part No. structure

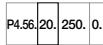

- Color
- Radius
- Width
- Series

Series P4.56 - rol e-chain® with combstipe autoglide cross bars

Part No.	Bi	Ba	R	Bending Radii							Weight [kg/m]
P4.56.20.	.0	200 270	150 200	250 300	350 400	450 500					≈ 6,89
P4.56.25.	.0	250 320	150 200	250 300	350 400	450 500					≈ 7,25
P4.56.30.	.0	300 370	150 200	250 300	350 400	450 500					≈ 7,65
P4.56.35.	.0	350 420	150 200	250 300	350 400	450 500					≈ 8,11
P4.56.40.	.0	400 470	150 200	250 300	350 400	450 500					≈ 8,50

The bending radii 150 | 200 | 400 | 450 | 500 are available upon request.

Delivery time: approx. 6-8 weeks after receipt of order!

Supplement Part No. with required radius. Example: P4.56.20.250.0

0 = standard color, other colors ▶ page 1.39

Pitch = 91 mm/link Links/m = 11 (1001 mm) Chain length = $S/2 + K$

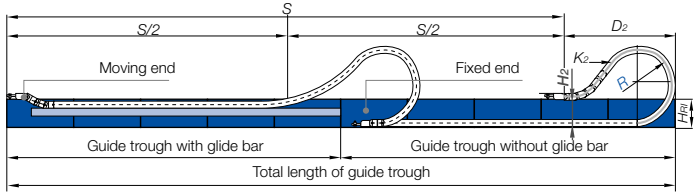

- S = Length of travel
- R = Bending radius
- H = Nominal clearance height
- H_F = Required clearance height
- H_{RI} = Trough inner height
- D = Overlength e-chain® radius in final position
- K = $\pi \cdot R + \text{"safety"}$
- D₂ = Overlength - long travels, gliding
- K₂ = "Further add-on"
- H₂ = "Mounting height"

*if the mounting bracket location is set lower

R	150°	200°	250	300	350	400°	450°	500°
H	390	490	590	690	790	890	990	1090
D	286	336	386	436	486	536	586	636
K	655	815	970	1125	1285	1440	1600	1755
H ₂	*	180	180	180	180	180	*	*
D ₂	*	1140	1470	1700	1950	2255	*	*
K ₂	*	1820	2275	2639	3003	3458	*	*

*upon request

Technical Data



Details of material properties

▶ page 1.38

Long travels	from 10 m up to max. 800 m
Speed max. rolling / acceleration max. rolling	max. 10 [m/s] / max. 50 [m/s ²]
Fill weight	max. 15 [kg/m]
Material - permitted temperature °C	igumid G / -40° up to +120° C
Flammability class, igumid G	VDE 0304 IIC UL94 HB

Additional Features



Interior separation available - Series E4.56
▶ from page 7.78



Extension link for heavy fill weights available
▶ upon request



Robust steel mounting brackets available
▶ upon request



Special P4 guide trough system available
▶ upon request

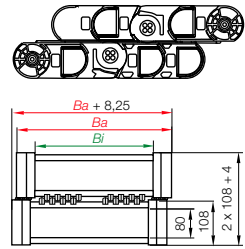
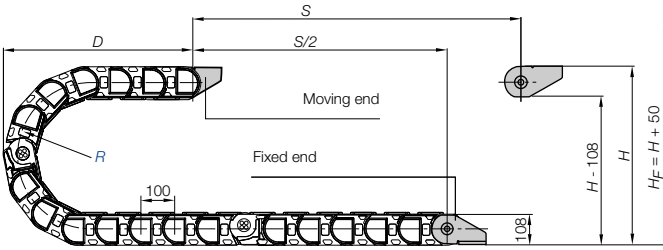

Series P4.80 - rol e-chain® with combstipe autoglide cross bars

Part No.	Bi	Ba	R	Bending Radii	Weight [kg/m]
P4.80.20.	200	276	150	200 250 300 350 400 450 500	≈ 8,46
P4.80.25.	250	326	150	200 250 300 350 400 450 500	≈ 8,79
P4.80.30.	300	376	150	200 250 300 350 400 450 500	≈ 9,02
P4.80.35.	350	426	150	200 250 300 350 400 450 500	≈ 9,58
P4.80.40.	400	476	150	200 250 300 350 400 450 500	≈ 9,93

The bending radii 150 | 200 | 400 | 450 | 500 are available upon request.

Delivery time: approx. 6-8 weeks after receipt of order!

Supplement Part No. with required radius. Example: P4.80.20. 250 | 0

0 = standard color, other colors ▶ page 1.39

Pitch = 100 mm/link Links/m = 10 (1000 mm) Chain length = $S/2 + K$

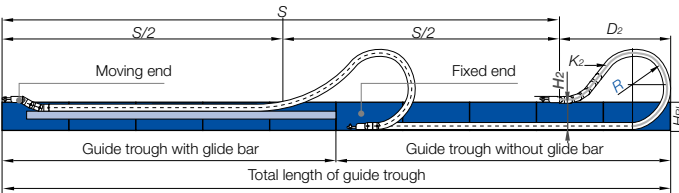

R	150*	200*	250	300	350	400*	450*	500*
H	420	520	620	720	820	920	1020	1120
D	310	360	410	460	510	560	610	660
K	675	830	990	1145	1300	1460	1615	1775
H ₂	180	180	180	180	180	180	180	180
D ₂	955	1310	1610	1974	2060	2625	2910	3275
K ₂	900	1400	1800	2300	2700	3200	36000	4100

*upon request

Long travels	from 10 m up to max. 800 m
Speed max. rolling / acceleration max. rolling	max. 10 [m/s] / max. 50 [m/s]
Fill weight	max. 15 [kg/m]
Material - permitted temperature °C	igumid G / -40° up to +120° C
Flammability class, igumid G	VDE 0304 IIC UL94 HB

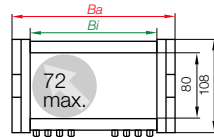

Part No. structure

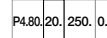

- Color
- Radius
- Width
- Series

- S = Length of travel
- R = Bending radius
- H = Nominal clearance height
- H_F = Required clearance height
- H_{RI} = Trough inner height
- D = Overlength e-chain® radius in final position
- K = $\pi \cdot R$ + "safety"
- D₂ = Overlength - long travels, gliding
- K₂ = "Further add-on"
- H₂ = "Mounting height"

*if the mounting bracket location is set lower

Technical Data



Details of material properties

▶ page 1.38



Interior separation available - Series E4.80
▶ from page 7.96



Extension link for heavy fill weights available
▶ upon request



Robust steel mounting brackets available
▶ upon request



Special P4 guide trough system available
▶ upon request

Additional Features



rol e-chain[®]

rol e-chain® - Rolling instead of gliding

e-chains® are being used in ever longer travels. This has driven the development of the rol e-chain®. Additionally, movement speeds are increasing in combination with larger and larger fill weights (up to 50 kg/m). **Please contact us if you have decided for this product. We'll assist you in the project planning!**

- Major reduction in drive power to less than 25 % for moving the e-chain®
- Travels up to 800 m possible
- Speeds up to 6 m/s possible
- Various roller types for optimum application adaption
- Can be used even in dirty environments
- Available as ready-to-fit, made-to-specifications system
- System guarantee for made-to-specifications systems

Application areas

The igus® rol e-chain® is designed for applications where long travels at high speeds have to be realized. This is, for instance, frequently the case with moving camera systems or material handling systems, even in the case of slower applications in the crane sector or travelling plants the low friction values of the system allow cost-savings, since the drives can be considerably smaller.

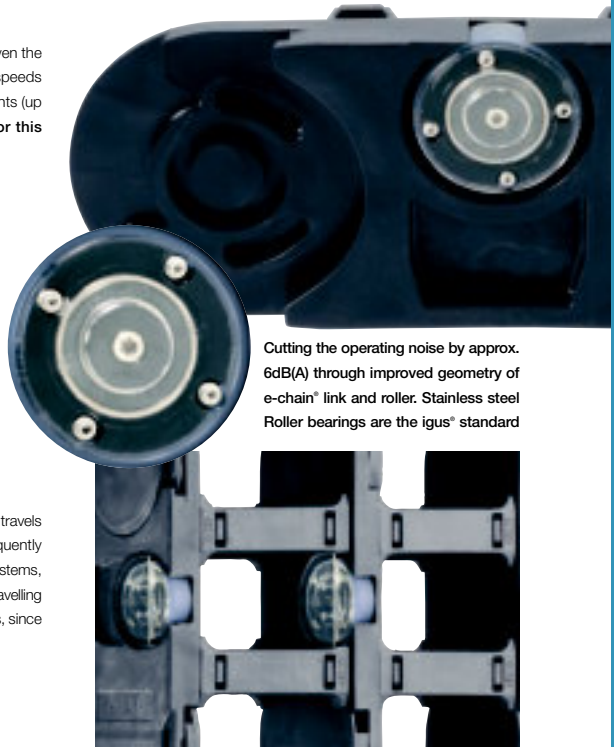

Cutting the operating noise by approx. 6dB(A) through improved geometry of e-chain® link and roller. Stainless steel Roller bearings are the igus® standard

Roller extension link for higher additional weights and widths up to 2 m and more



Cross travel of 441.3 m, implemented with igus® rol e-chain® Series 5050R

Product Range rol e-chain®

Interior heights of 32, 42, 56 and 80 mm and widths of 50 mm up to several meters are possible and are available from stock. All interior separation options and mounting bracket variants of the igus® system E4 are available. The standard guide troughs of the relevant e-chains® from stock can be used rol e-chains® can basically be opened along both radii. The rol e-chain® is available as a made-to-spec e-chainsystem®. The rol e-chain® standard are stainless-steel ball-bearings. It is fitted with chainflex® cables and made-to-

spec connectors and fittings in accordance with your requirements by igus® specialists and packaged in installation-friendly manner. Depending on the length of travel, the rol e-chain® can be delivered on a drum. If cables from the chainflex® range are to be used, we will be more than willing to assume warranty for the full system. **Systems of this type should be designed by our system design engineers. We will be more than willing to submit an offer to you. Please contact us about this.**

Selection table

Series	Inner height <i>hi</i> [mm]	Inner width <i>Bi</i> [mm]	Outer width <i>Ba</i> [mm]	Outer height <i>ha</i> [mm]	Bending radius <i>R</i> [mm]	Chapter
rol e-chain® - with crossbars every 2nd link						
2828R	32	50 - 400	73 - 423	54	125 - 300	7
3838R	42	50 - 400	77 - 427	64	150 - 350	7
4040R	56	50 - 600	86 - 636	84	200 - 500	7
4040 RHD*	56	50 - 600	140 - 654	84	200 - 500	7
5050R	80	50 - 600	100 - 650	108	250 - 500	7
5050 RHD*	80	50 - 660	160 - 710	108	200 - 500	7
rol e-chain® - e-tube, fully enclosed						
R7728R	32	50 - 300	73 - 323	54	250 - 300	7
R7838R	42	50 - 300	77 - 327	64	200 - 350	7
R8840R	56	75 - 462	111 - 499	84	300 - 500	7
R9850R	80	75 - 462	125 - 513	108	300 - 1000	7

- 4040 RHD* / 5050RHD* = extra stable version of Series 4040 and 5050
- 5050R: for e-chain® widths up to 3000 mm with extension link/roller extension link
- Series 2828R, 3838R, 4040R, 5050R are also available as autoglide rollers
- Details on the appropriate E4/4 Series ► chapter 7 - System E4/4

Proven advantage: Reduce push-pull forces over 75% with igus® rol e-chain®

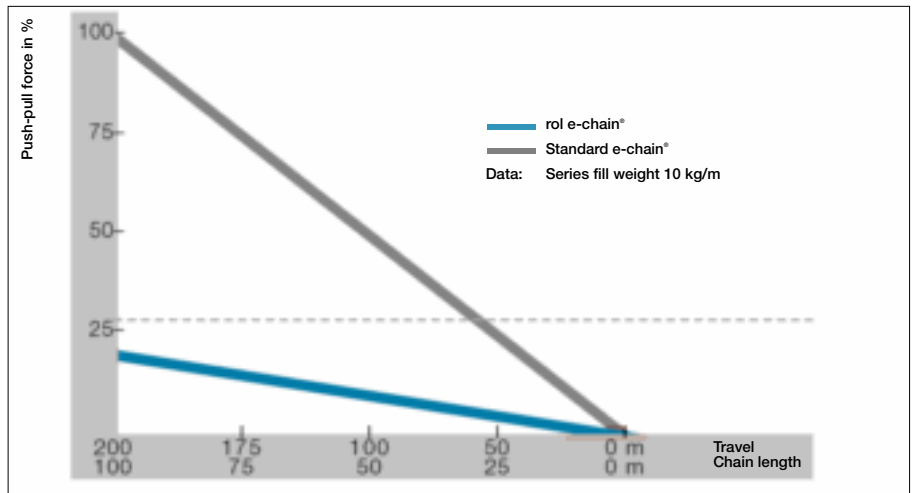

Comparison of the power requirement between rol e-chain® and a standard e-chain®



igus® rol e-chain® Serie 5050R in a steel plant in india with highly corrosive atmosphere - $s = 22\text{ m}$, $v = 1\text{ m/s}$, $a = 1\text{ m/s}^2$



Power plant application with igus® rol e-chain® 4040R - Travel 46 m, Speed 1.5 m/s, Fill weight 5.3 kg/m



Assembled system in a ship unloading crane with igus® 5050RHD - Travel 106 m, Speed 4 m/s, Fill weight 25 kg/m



Series 4040R on a coal unloading system - Travel 190 m, Speed 0.5 m/s, Fill weight 8.05 kg/m



Series 4040R in steel works environment - Travel 10.5 m, Speed 60 m/min, Fill weight 6.084 kg/m



igus® e-chains® 5050RHD "rol e-chain" in an igus® super-alu-trough = 75% less driving power

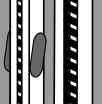
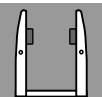
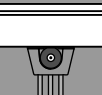
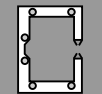
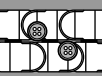
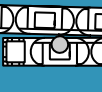
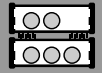



autoglide

autoglide:

Long travels are always demanding for an e-chainsystem[®]. For much of the travel, the e-chain must run on the lower run or on the glide bars. In addition the e-chainsystem[®] needs guides, in order to prevent a sideward movement. In most cases this is ensured through a guide trough. However, there are also applications where a guide trough is not desired for space reasons, whether this is due to optical considerations or spatial conditions. In order to cater for this possibility, igus[®] developed the autoglide system in 1995. autoglide is a self-aligning e-chain[®], which can dispense with guide troughs for up to 50 m travel. You save acquisition and installation costs and can keep pathways in your warehouse free for Klifts or industrial trucks.

- Travels up to 50 m
- Travel speeds up to 1,5 m/s
- autoglide e-chain[®] links of a piece, no additional parts required
- Very quick installation times for long travels
- Guide troughs not required!
- Small installation width, silent operation
- Functional guarantee for the entire system with chainflex[®] cables



In principle every igus[®] e-chain[®] can be fitted out for the autoglide system. However, we recommend its use with e-chain[®] whose interior height is less than 35 mm, and you should also consult us, since there are restrictions regarding the bending radii to be used

There are 4 options of the igus[®] autoglide system:



Option 1 - is available for almost all System E4 Series - here the crossbars in the interior radius of the e-chain[®] are fitted with molded-on glide shoes

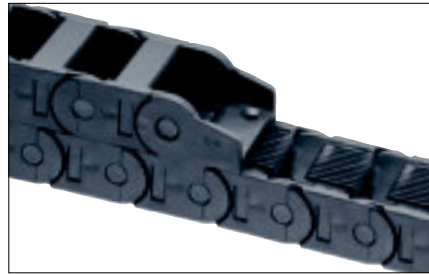

Option 2 - for Series 200 e-chains[®]: Injection-molded autoglide grooves in the inner radius. One-piece e-chain[®] with firmly molded horizontal interior separation

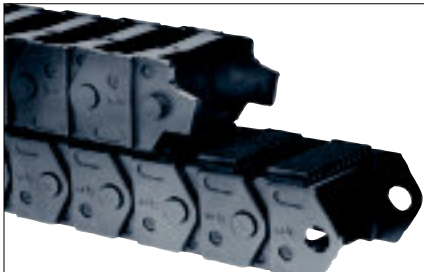

Option 3 - for igus[®] easy chain[®] e-chain[®] combination of the easily fillable easy chain[®] and injection-molded autoglide grooves in the inner radius

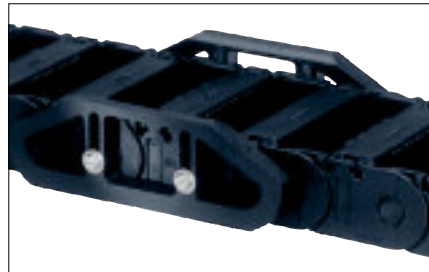

Option 4 - for Series E2/000 e-chain[®] - Special plastic glide shoes side-mounted on the e-chain[®] hold the e-chain[®] "in the track"



1 autoglide e-chain® with assembled glider

Part No. structure

E4.56	21	250	0	OF
-------	----	-----	---	----



- Complete unit
- autoglide
- color
- Radius
- Width
- Series



2 autoglide e-chain® with separate glider (unassembled)

Part No. structure

E4.56	21	250	0	OF
-------	----	-----	---	----



- autoglide
- color
- Radius
- Width
- Series

Option 1: autoglide for System® E4.1 up to 56 mm interior height

Large gliding surfaces and good sliding behavior - Of one piece, no additional parts required. Option 1 is available for the larger e-chains® of System E4.1 (E4/4 and E4/00 upon request) - here the crossbars in the interior radius of the e-chain® are fitted with molded-on glide shoes. With autoglide the length of the e-chain® can be the entire travel plus add-on for the bending radius.

- 1 autoglide e-chain® with assembled glider
- 2 autoglide e-chain® with separate glider (unassembled)
- 3 Glider and floor guide as single parts

System E4.1 autoglide variants (autoglide crossbars along the inner radius)

Part No.		Bi	Ba	R	ending radius													
E4.32.112.	<input type="checkbox"/>	0.0	112	136	100	125	150	175	200	220	250	300						
E4.32.12.	<input type="checkbox"/>	0.0	125	148	100	125	150	175	200	220	250	300						
E4.32.15.	<input type="checkbox"/>	0.0	150	173	100	125	150	175	200	220	250	300						
E4.32.17.	<input type="checkbox"/>	0.0	168	191	100	125	150	175	200	220	250	300						
E4.32.20.	<input type="checkbox"/>	0.0	200	223	100	125	150	175	200	220	250	300						
E4.32.262.	<input type="checkbox"/>	0.0	262	286	100	125	150	175	200	220	250	300						
E4.42.112.	<input type="checkbox"/>	0.0	112	139	100	115	125	150	170	200	115	250	300					
E4.42.12.	<input type="checkbox"/>	0.0	125	151	100	115	125	150	170	200	115	250	300					
E4.42.15.	<input type="checkbox"/>	0.0	150	176	100	115	125	150	170	200	115	250	300					
E4.42.17.	<input type="checkbox"/>	0.0	168	194	100	115	125	150	170	200	115	250	300					
E4.42.20.	<input type="checkbox"/>	0.0	200	226	100	115	125	150	170	200	115	250	300					
E4.42.262.	<input type="checkbox"/>	0.0	262	289	100	115	125	150	170	200	115	250	300					
E4.56.15.	<input type="checkbox"/>	0.0	150	184	135	150	175	200	240	250	300	350	400	500				
E4.56.21.	<input type="checkbox"/>	0.0	212	247	135	150	175	200	240	250	300	350	400	500				
E4.56.25.	<input type="checkbox"/>	0.0	250	284	135	150	175	200	240	250	300	350	400	500				

autoglide also available for Series 280, 2828, 380, 3838, 400, 4040 and 5050

Supplement Part No. with reqired radius. Example: E4.56.21. 250.0

Further widths on request - Delivery time: approx. 6-8 weeks after receipt of order!



3 autoglide glider and floor guide as single parts. Glider and floor guides every 2 m completely replace a guide trough

Long travel without guide trough - Glider and floor guide

Simple guide elements for quick installation on the subsurface are available for the autoglide system version 1. The traversable exocentric floor guides are fastened every 2 m on the subsurface. The glider fastened on the moving end feeds the e-chain® and holds this securely in the track. The autoglide crossbars safely guide the e-chain® and replace the guide trough. ● Save purchase and installation costs with this system ● Traversable over floor guide for travel distances over 10 m. **Note:** Only 2 gliders **OF** are required for the safe feeding of the e-chain®. The mounting of the glider is done on the outer link of the upper run, which is laid down first on the lower run.



Glider and floor guide as single parts

Floor guide, set (single part, left and right)	For Series
380.B	universal
Glider (single part, without screws)	For Series
280.OF	E4.32 / 280 / 2828
380.OF	E4.42 / 380 / 3838
400.OF	E4.56 / 400 / 4040



Industrial trucks can run over the floor guides

Roller autoglide RAG

Special feature: Series 4040 and 5050 also available as rolling autoglide. For long travel and 75% less drive power (gliding application). We request for a consultation in case you have decided on this product.



System E4 Roller autoglide options

Part No.	Bi	Ba	R	Bending radius										
4040.28.	0.RAG	287	324	135	150	175	200	240	250	300	350	400	500	
4040.36.	0.RAG	362	399	135	150	175	200	240	250	300	350	400	500	
5050.28.	0.RAG	287	338	150	200	250	300	350	400	500	550	600	650	1000
5050.36.	0.RAG	362	413	150	200	250	300	350	400	500	550	600	650	1000

Supplement Part No. with required radius. Example: 4040.28.150.0.RAG

Comprehensive information for each E4 Series can be found at the relevant catalog page

Series	Inner-height <i>hi</i>	Outer-height <i>ha</i>	Page	Series	Inner-height <i>hi</i>	Outer-height <i>ha</i>	Page
E4.32	32	54	7.42	E4.56	56	84	7.78
280	32	54	7.264	400	56	84	7.284
2828	32	54	7.318	4040*	56	84	7.342
E4.42	42	64	7.60	E4.80*	80	108	7.96
380	42	64	7.274	5050*	80	108	7.362
3838	42	64	7.330				*Also available as autoglide e-chain*

Part No. structure

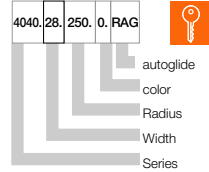

autoglide

autoglide | Product Range | Option 2

Option 2: Series 200 - Molded autoglide grooves in the inner radius

One-piece e-chain* with molded autoglide grooves in the inner radius. Available in one width, with molded horizontal interior separation.

- autoglide e-chain* links are moulded and no additional parts are necessary
- Guide troughs not required!
- Narrow construction width, quiet running
- Function guarantee on the whole system with chainflex* cables



R = Bending radius
 H_2 = Mounting height
 (if the moving end is set lower)
 D_2 = Over length - long travels, gliding
 K_2 = Further add-on
 (if the moving end is set lower)

Series AG200 - Combination: autoglide and E2 medium (Series 200)

Part No.	Bi	Ba	R	Bending radius								
AG200.05.	0	57	73,2	055	075	100	125	150	175	200	225	250

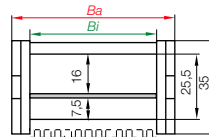

Supplement Part No. with required radius. Example: AG200.05.055.0

Pitch = 46 mm Links/m = 22 Chain length = $S + K$

R	055*	075	100	125	150	175	200	225	250
H_2	110	150	100	100	100	100	100	100	100
D_2^{+25}	142	162	380	440	590	755	950	1040	1130
K_2	265	330	644	736	1012	1242	1472	1610	1794

The required clearance height is: $H_F = H + 25$ mm, must be noted in all types of applications



Part No. structure

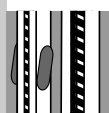
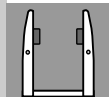
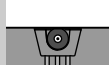
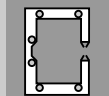
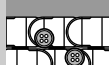
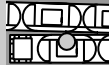
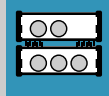
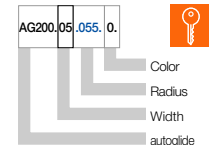



Option 3: As EA16 and EA25

The version 3 is a combination of autoglide version 2 and easy chain®. The grooves similar to tie-wrap plates are molded directly on the e-chain® link and available at present in two sizes.

- autoglide e-chain® links of a piece, no additional parts required
- Very quick installation times for long travels
- Guide troughs not required!
- easy chain® system: Cables and hoses can be inserted without opening the e-chain®
- Small installation width, silent operation
- Functional guarantee for the entire system with chainflex® cables

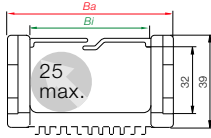

Series EA16 - Combination of autoglide and easy chain®

Part No.	Bi	Ba	R Bending radius
EA16.4. <input type="text"/> .0	48	60	<input type="text"/> 060 <input type="text"/> 075 <input type="text"/> 100

Supplement Part No. with required radius. Example: EA16.4. 060.0



Mounting bracket

with strain relief (full set) Part No. EA16.4.12PZ

Part No. structure

EA16. 4. 060. 0.



- Color
- Radius
- Width
- Easy autoglide

Pitch = 30,5 mm Links/m = 33 Chain length = S + K

R	060	075	100	*
H	159	189	239	
D	125	140	165	
K	250	300	380	

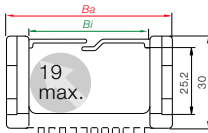

Series EA25 - Combination of autoglide and easy chain®

Part No.	Bi	Ba	R Bending radius
EA25.050. <input type="text"/> .0	50	60	<input type="text"/> 075 <input type="text"/> 100

Supplement Part No. with required radius. Example: EA25.050. 075.0



Mounting bracket

with strain relief (full set) Part No. EA25.050.12PZ

Part No. structure

EA25.050. 075. 0.



- Color
- Radius
- Width
- Easy autoglide

Pitch = 25 mm Links/m = 40 Chain length = S + K

R	075	100
H	180	230
D	135	160
K	290	375



guidelok horizontal

Upper run guide for long travels, self-supporting in chip areas

Especially for long travels on machine tools, if the e-chain® has to be gliding, metallic chips are a problem. guidelok horizontal is a cost-effective solution

- Travels, unsupported up to 50 m possible
- Chips cannot get stuck between upper and lower run
- Modular system with few parts
(also possible without sideways trough)
- Enormous increase of „self supporting“ length of e-chains®
- Lower push-/pull forces (smallere-chains®, self supporting and rollers = energy efficient)
- Systeme Lower cost than most steel chains or sophisticated gliding systems
- Open guide trough design, chips can fall through

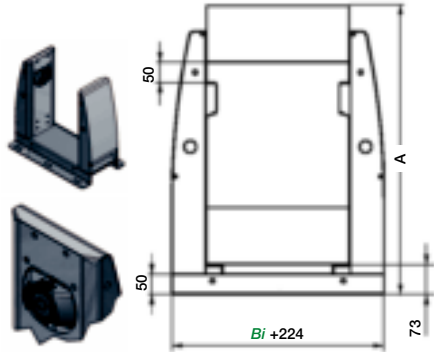

Typical industries and applications

- Machine tools ● Applications in the chip area
- Wherever a gliding application is not recommended

Design-principle - horizontal guidelok guides the e-chain® on special spring loaded roller supports, that are pushed back by the e-chains® radius, clearing its path



The e-chain® is guided in the trough channel, pushing back the spring loaded roller support with its radius...



...which snaps back out again after the e-chain® radius has passed...



...the upper run then gets to lay on the roller support.

guidelok horizontal | Product Range

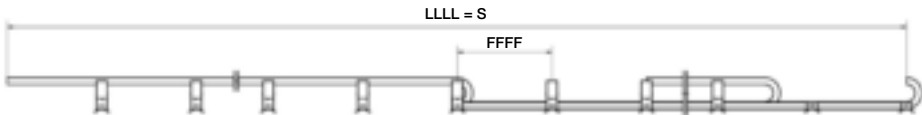

Principle sketch - guidelok horizontal

Selection table

For Series	Bi	R Bending radius	Dim. A	Part No. horizontal trough with guidelok	
E4.56/R4.56	50 - 600	150, 175, 200, 250, 300		907.645.Bi.R.LLLL/FFFF	LLLL = Total length
E4.80/R4.80	50 - 600	150, 175, 200, 250, 300		907.645.Bi.R.LLLL/FFFF	FFFF = Field length
600/R608	200 - 600	150, 175, 200, 250, 300		907.645.Bi.R.LLLL/FFFF	
E4.56/R4.56	50 - 600	350, 400, 450, 500		907.837.Bi.R.LLLL/FFFF	For many more types (widths/radii) possible, due to the modular design - please contact us
E4.80/R4.80	50 - 600	350, 400, 450, 500		907.837.Bi.R.LLLL/FFFF	
600/R608	200 - 600	350, 400, 450, 500		907.837.Bi.R.LLLL/FFFF	

A close-up, vertical view of a cable car system. The image shows the dark metal support structure, including vertical rails and a horizontal track. A cable car cabin is visible at the bottom, blurred to indicate motion. The background is a solid, bright blue color. The text "guidelok slimline 'F'" is overlaid in white on the left side of the image.

guidelok slimline "F"

guidelok slimline "F": Safe vertical guidance for e-chains[®] in high-speed rack feeders

In highly dynamic rack feeder a speed for the horizontal movement exceeding in 6 m/s is not uncommon. The advanced igus[®] guidelok slimline F guides e-chains[®] even at the fastest speed.

- β to 7 m/s and 10 m/s ²
- β to 80% less trough required
- Saving costs and weight
- For hanging systems up to 50 m
- No swinging of the e-chain[®], high reliability through lever mechanism and guiding rails
- Faster and easier installation
- Reduced noise
- Easy access for servicing
- Energy and data and all kinds of media are safely guided without interruptin in one single system



Typical industries and applications

Storage and retrieval units, lifts, elevators, construction and crane lifts, hoists



Note: Systems of this type should be designed by our system design engineers. We will be more than willing to submit an offer to you. Please contact us about this.



Find a video online
www.igus.eu/gisl-f.movie

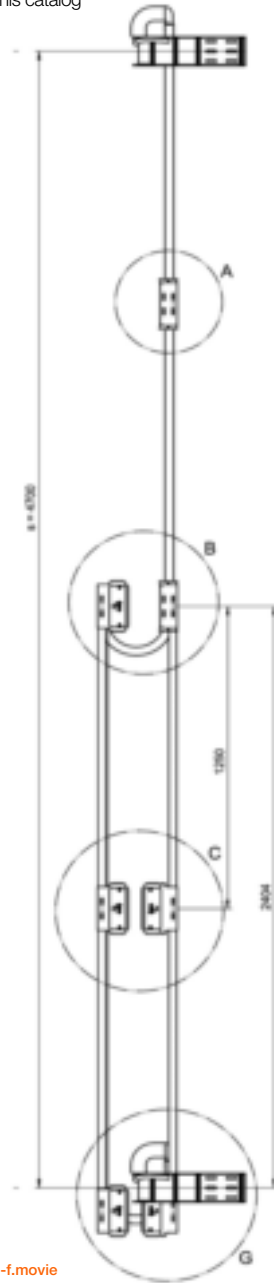

Selection table

For Series	Bi	R Bending radii	Part. No. vertical trough with guidelok LLLL =total length/height
255	100	125	GLSL.F.255.10.125.LLLL/FFFF

More sizes/dimension upon request!



lbt flizz[®]

lbt flizz® - High speeds and accelerations

- Travels up to 120 m, speeds up to 8 m/s
- Applicable for moving and stationary control, ideal for all bus systems
- Good for applications needing low weight and good corrosion resistance
- Quiet and maintenance free operation
- At -10°C up to +60°C continuous temperature
- Accelerations over 10 m/s²
- Energy supply for all media, not only for electrical
- Also suitable for outdoor use
(with reduced load data)

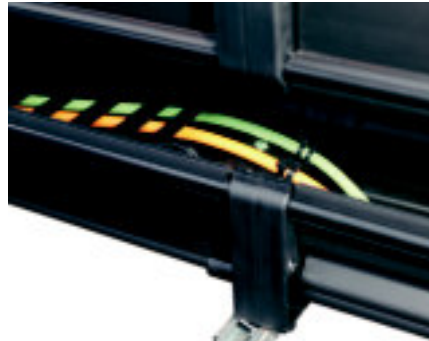

lbt flizz® System

The complete system comprises the igus® e-chain®, the lbt flizz® guide trough and the igus® chainflex® cables which can be fully made-to-spec on request. The lbt flizz® guide trough consists of a modular system, based on extruded guide profiles and a supporting frame with continuous tubes for stabilization. All components are of corrosion-protection, made either extruded or powder-coated high-quality plastic. The materials used are resistant to weathering and resistant to most chemicals, oils, greases, coolants and solvents. The optionally fully enclosed design offers protection against dirt, leaves, ice and snow. Safety, function and freedom from maintenance with clear price advantages over conventional energy supply systems are the crucial criteria for selection.

Advantages of lbt flizz®

- Guaranteed service life
- Cost-effective by comparison with conventional energy supply systems
- Protection of the cables against dirt, rain, sun, ice, snow and leaves
- Insensitive to wind movement
- Resistant to chemicals and solvents etc.
- Use of special cables possible, e.g. servo-drive cables, fiber-optic cables and bus systems etc.
- Virtually maintenance-free
- Easy and fast installation since it supplied as a made-to-spec system
- Easy integration in existing systems
- Cable length 50 % of travel

Typical industries and applications

- Sludge scrapers
- Sand catchers
- Stormwater overflow tanks
- Electric plating plants
- Cranes
- Plant construction

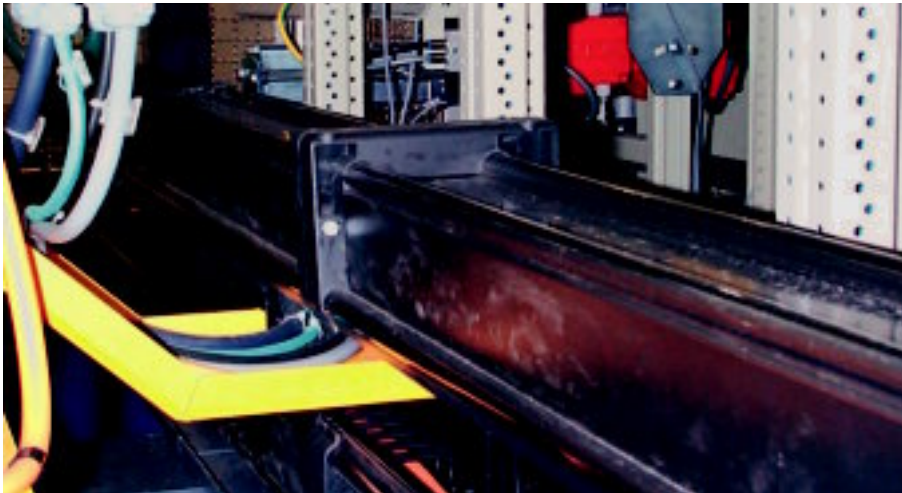

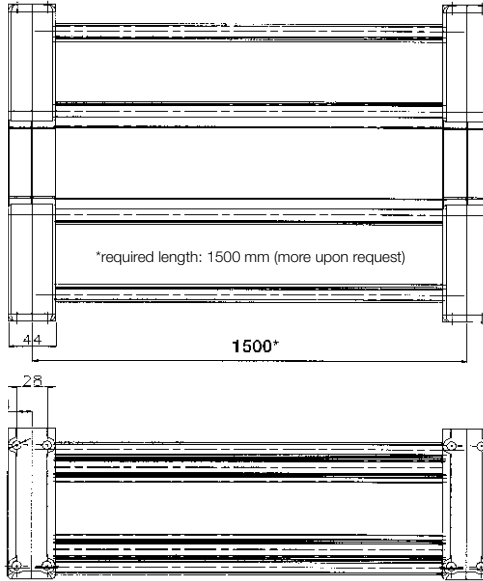
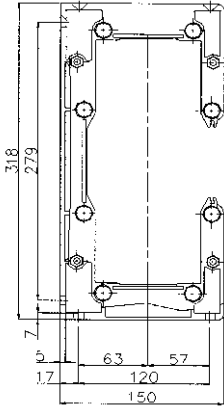

Installation variant for
power infeed at fixed end



Example of mounting
the console on jibs



Design

- Solid plastic with powder-coated support tubes
- Modular design: the system can be closed with intermediate plates!
- Can be supplied preassembled
- Variable bays which are simply screwed together
- Glide bar integrated in profile

Safe energy and data transfer

The igus® chainflex® range of cables offers a selection from over 850 different cables available from stock. This includes power, signal, data and bus systems including fibre optic cables. In addition, we can offer you all supply cables for your drive systems, such as motor, servo cables and encoder cables; all can be supplied made-to-spec with connectors.

Cost-cutting installation

Thanks to the use of made-to-spec e-chainsystems®, you can greatly reduce expensive time incurred for installation and assembly at the installation site. Function-tested systems guarantee fast commissioning of the powered system sections.

Installation service

We will be more than pleased to submit an offer to you for a full solution, including all installation services. This means that none of your own staff are tied up and, in future, you will have a trouble-free energy supply system at a fixed price.

Outdoor use in sewage treatment plants

Because of the particular strain in sewage treatment plants, some with flooding, foam, etc., a safety margin for all load values of 50%, compared to applications in the inner/dry zone, should be made. A review of the application data by our project engineers is recommended.

The installation variant of a floating moving end for compensating for any lateral offset tolerances between scraper and e-chainsystem®



The scraper moves on the 38 m long final clarifier in round-the-clock operation. The energy supply is done via the lbt flizz® system



Space-saving and compact energy supply with lbt flizz® - Maintenance system, delivered pre-assembled with assembled igus® e-chain®



lbt flizz® in a longitudinal scraper travel (S) = 38 m

- Speed (v) = 1.0 m/min.
- Acceleration (a) = 0.5 m/s²
- Cycle time 1.5 x hour/ 24 h/365 days



Energy supply system protected from wind and weathering. The used materials are weather-resistant, as well as resistant against most chemicals, oils, fats, coolants and solvents



igus® lbt flizz® - Sewage works of the company Hydrobudowa S.A. in Poland. The power supply system of the scrapers in 8 clarifiers was equipped with igus® e-chain® and lbt flizz®. The complete system runs directly over the clarifier. Advantages: ● Low-maintenance system ● Longer service life ● Enclosed trough, protection against snow and ice ● Space-saving compared to conventional system ● Compact and safe ● Travel (S) = 42 m ● Assembled with igus® chainflex® cables

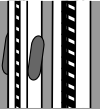
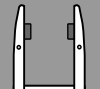
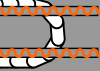
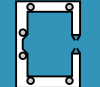
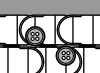
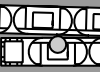
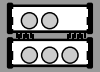



micro flizz®



Master long travels with the smallest e-chain® without failures

- ONE compact system for a secure guidance of power, data and air
- Maintenance-free alternative for busbar
- e-chain® is guided in special slot, no sliding against each other
- Control via stationary switch cabinet possible
- Accelerations up to 50 m/s² and speeds up to 6 m/s
- Fast assembly due to pre-configured, modular system
- Less space required
- Available also as pre-assembled
- Smooth running due to ball bearings in the guide carriages
- Also with EX tested e-chain® available (on request)
- Rail material: anodized aluminum
- iF-Design Award

Cable diameter
 MF06: max. Ø 8,0 mm
 MF08: max. Ø 9,5 mm

Typical industries and applications

- Rack feeder ● Indoor cranes ● Industrial gates ● Working stations ● Sewage treatment plants ● Camera systems ● Sliding doors ● Operator panels ● Measure systems ● Studio equipment ● Conveyor technique



Special feature of the micro flizz® construction

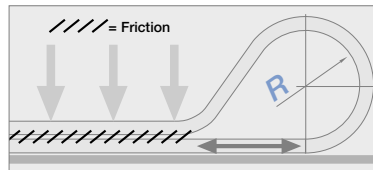

Yesterday: Moving lower run, sliding function. Long travels need stable e-chains®.

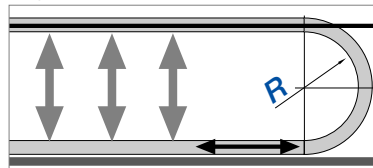

Today: micro flizz® - Small e-chains®, self-guiding in guiding channel - Friction is reduced by factor 3 over the conventional system.

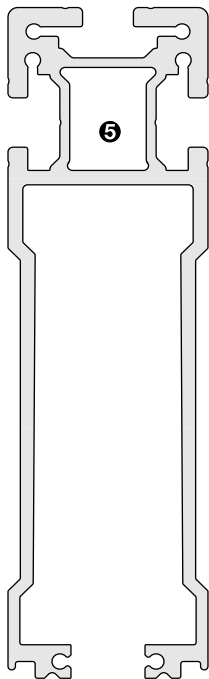

Technical data micro flizz®

- ❶ Separated upper and lower run of the flizz® e-chain®, thus less friction and reduced push/pull forces
- ❷ Winglets hold the e-chain® secure in the guidance channel
- ❸ Polymer springs for a soft unrolling of the e-chain® in the flizz® channel effect a substantial noise reduction
- ❹ Integrated strain relief in the guide carriage for the safe fixing of cables
- ❺ Universal attachment options due to three T-grooves
- ❻ Attachment of the e-chain® by roller cart on the moving end, gliding or locking possible
- ❼ Opposed e-chains® can be used, that means a double filling or two independent travels are possible

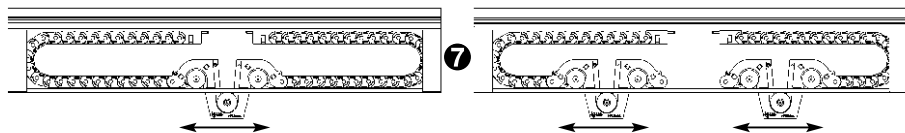
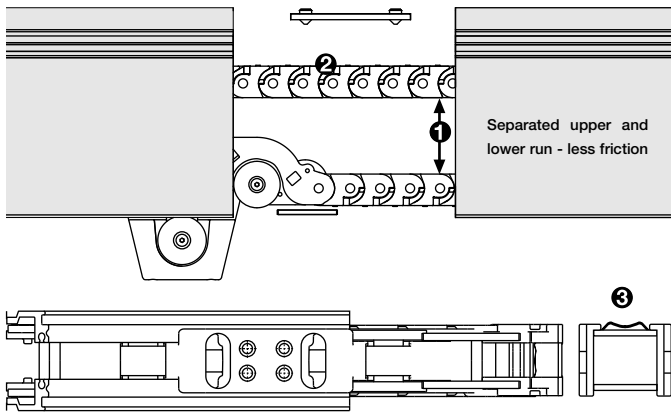

Details micro flizz®



Separated upper and lower run: Running trough the radius, integrated winglets fold in

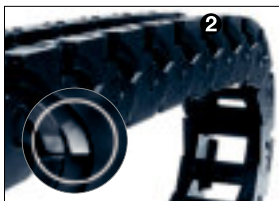

In the extended position, the winglets fold out and safely hold the upper run in the elevated position

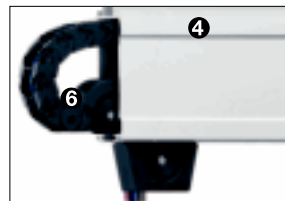

Power, data, pneumatics in confined areas. chainflex® cables are specifically designed for this challenge

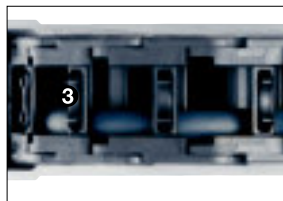

A polymer spring element cushions the motion inside the trough and lower noise



micro flizz® accessory:
Connection for compressed air coupling



Potential application area of the micro flizz® - Storage and retrieval units for high-bay warehouses, indoor cranes, etc.

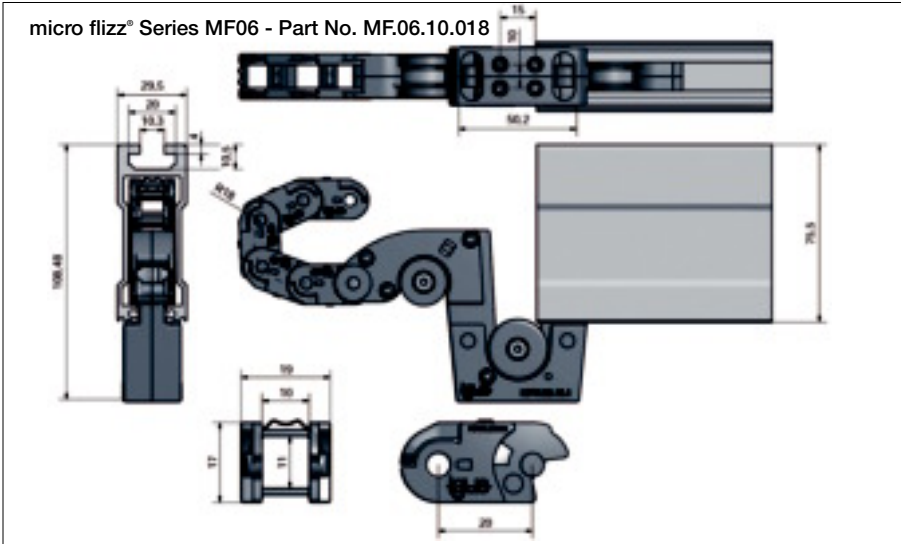

micro flizz® Series MF06 - Dimensions

Part No.	Bi	Ba	hi	ha	R Bending radius
MF.06.10.018	10	19	11	17	018

order example ► next page

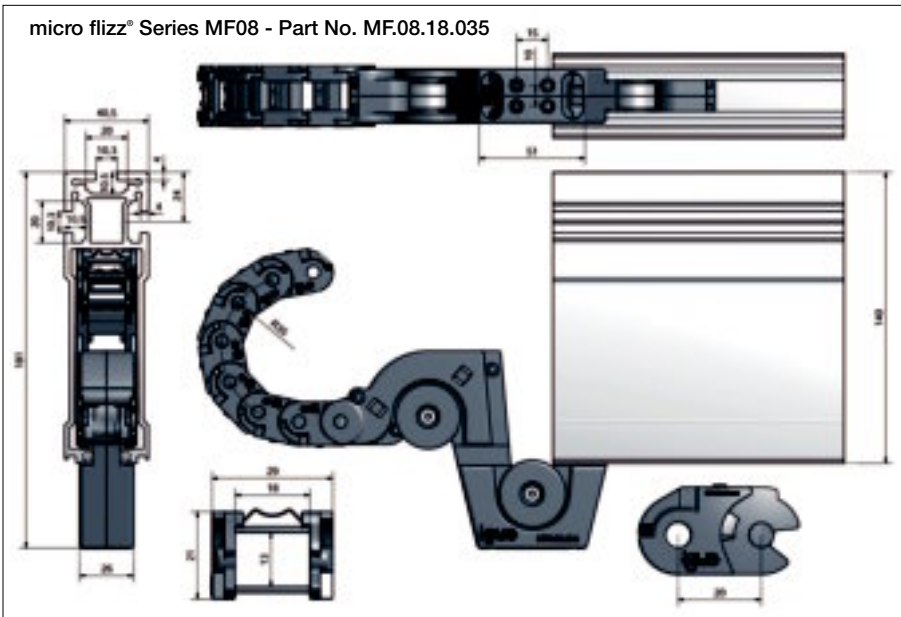

micro flizz® Series MF08 - Dimensions

Part No.	Bi	Ba	hi	ha	R Bending radius
MF.08.18.035	18	29	13	21	035

order example ► next page



Order example - End feed

MF	06.	10.	018.	L / F
MF	08.	18.	035.	L / F

MF.06.10.018.5000/2000 Series MF06

MF.08.18.035.5000/2000 Series MF08

- F = Field length [mm]
- L = Total length [mm]
- R = Bending radius [mm]
- Bi = Inner e-chain® width
- Type (Series)
micro flizz® **end feed**.

Calculate the number of required channel pieces (n) thus:
 $n = \frac{L}{F}$
 Then round off the result.

micro flizz® as end feed option with a total length of 5000 mm, split into 2 channels each 2000 mm and 1 channel with a residual length of 1000 mm

- Bi = Inner e-chain® width [mm]
- R = Bending radius [mm]
- n = Number of channel pieces
- S = travel = L - 300 [mm]
- F = Field length [mm]
- L = Total length [mm]
- X = residual length [mm]

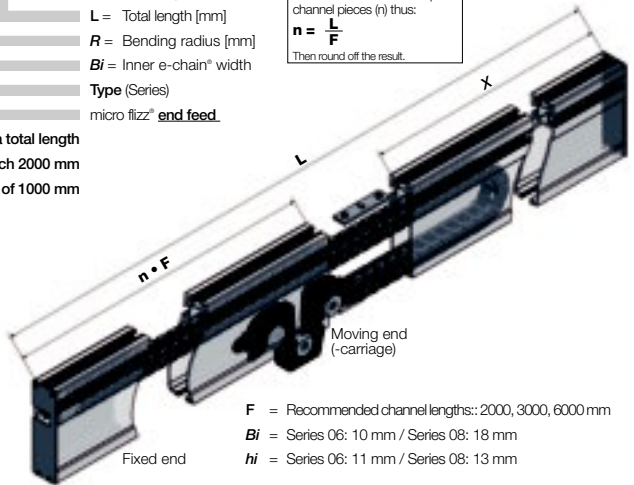

- F = Recommended channel lengths:: 2000, 3000, 6000 mm
- Bi = Series 06: 10 mm / Series 08: 18 mm
- hi = Series 06: 11 mm / Series 08: 13 mm



Order example - 2 carriages in opposite directions

MFG2	06.	10.	018.	L / F
MFG2	08.	18.	035.	L / F

MFG2.06.10.018.10000/3000 Series MF06

MFG2.08.18.035.10000/3000 Series MF08

- F = Field length [mm]
- L = Total length [mm]
- R = Bending radius [mm]
- Bi = Inner e-chain® width
- Type (Series)
micro flizz® **2 carriages**
in opposite directions

Calculate the number of required channel pieces (n) thus:
 $n = 2 \cdot \frac{L - 200}{2 \cdot F}$
 Then round off the result.



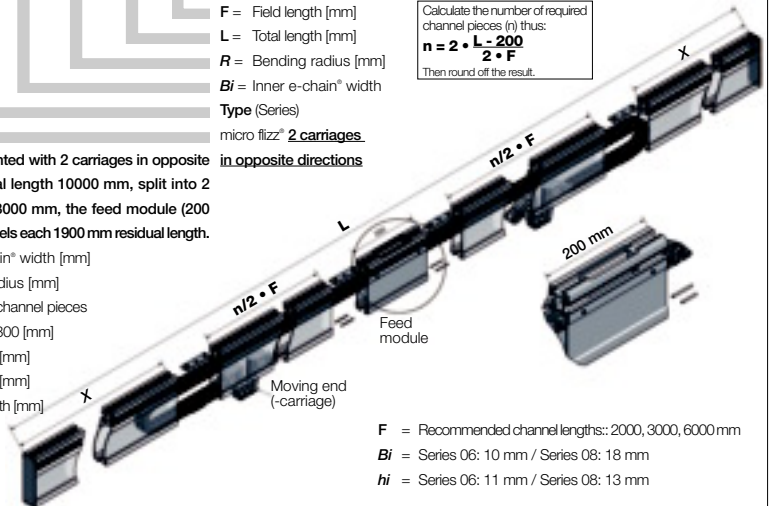

micro flizz® mounted with 2 carriages in opposite directions - Total length 10000 mm, split into 2 channels each 3000 mm, the feed module (200 mm) and 2 channels each 1900 mm residual length.

- Bi = Inner e-chain® width [mm]
- R = Bending radius [mm]
- n = Number of channel pieces
- S = travel = L - 300 [mm]
- F = Field length [mm]
- L = Total length [mm]
- X = residual length [mm]



- F = Recommended channel lengths:: 2000, 3000, 6000 mm
- Bi = Series 06: 10 mm / Series 08: 18 mm
- hi = Series 06: 11 mm / Series 08: 13 mm

Highly flexible chainflex® special cables for dynamic applications

chainflex®	Temp. [°C]	v max. unsupported	v max. gliding	a max.	Number of cores	Diameter ø [mm]
 CF.9	-35°C - +100°C	10 m/s	6 m/s	100 m/s ²	2 - 36	0,25 - 35,0
 CF.10	-35°C - +100°C	10 m/s	5 m/s	100 m/s ²	2 - 25	0,14 - 4,0
 CF.98	-35°C - +90°C	10 m/s	6 m/s	100 m/s ²	2 - 8	0,14 - 0,5
 CF.99	-35°C - +90°C	10 m/s	6 m/s	100 m/s ²	2 - 8	0,14 - 0,34
chainflex®	Temp. [°C]	v max. unsupported	a max.		Number of cores	Diameter ø [mm]
 CF.FLAT	-35°C - +90°C	10 m/s	*		1	2,5 - 50,0

*up on request

chainflex® cables suitable for micro flizz® are available from stock at igus®!

MF06 - max. cable outer diameter ø 8.0 mm, MF08 - max. cable outer diameter ø 9.5 mm

igus® micro flizz®

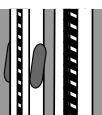
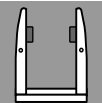
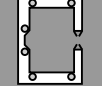
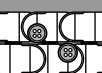
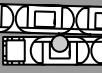
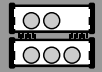



micro flizz® in an outdoor application with 30 m travel



Energy supply to the strip at cold storage house doors, in operation for more than one year.



micro flizz® as "energy supplying rail guide" of a scale to weigh chemicals, etc.



Safe energy supply also under strong dust and dirt accumulation with igus® micro flizz®



● $s = 8,5 \text{ m}$ ● $v = 4 \text{ m/s}$ ● $a = 4 \text{ m/s}^2$ ● Filling: 1x CF9.15.04 ● Running performance ca. 15.000 km without failure (issue 06.2006)



● $s = 40 \text{ m}$ ● $v = 4 \text{ m/s}$ ● $a = 1 \text{ m/s}^2$ ● $m_{\text{Chain}} = 0,21 \text{ kg/m}$ ● $m_{\text{Cable}} = 0,09 \text{ kg/m}$ ● Filling: 1 x CF98.05.04

igus® micro flizz®

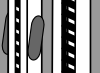
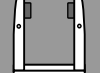
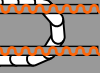
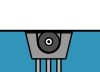
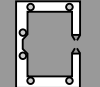
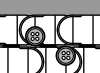
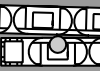
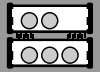



levichain

levichain - magnetic e-chainsystem® - it "floats"

The principle of the magnetic "floatation" is based on the attractive forces of the prevailing magnetic field, which "centers" the e-chain in all directions. By this "centering" the e-chain moves almost contactless with favorable friction and wear behavior and minimum abrasion.

- Long travel possible without laying the e-chainsystems® on top of each other
- Almost no abrasion and very low wear due to low-abrasion e-chain® links (without pin/hole connection) as well as almost contactless movement of the e-chain®
- Compared to other energy supply systems, the igus® System levichain is extraordinarily low noise [41.7 dB (A) in 1 m distance], as there is almost no rolling or sliding noise
- High speeds and accelerations are possible
- Simple assembly, even as a retrofit
- Variable installation positions (horizontal and vertical) possible
- Little space requirement in height and width
- IPA certificate



Long travels up to 40 m with high speeds and accelerations, almost contactless, with the igus® levichain

Typical industries and applications

- Cleanrooms
- Painting works/plants
- Medical technology
- Measuring technology
- Electronic manufacturing
- Automated storage and retrieval systems
- Material handling
- Industrial robots

Applications-levichain

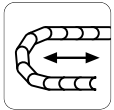

Unsupported applications

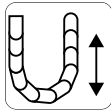

Vertical hanging applications

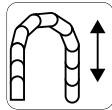

Vertical standing applications



Simple insertion of cables through the proven and tested "Easy" design

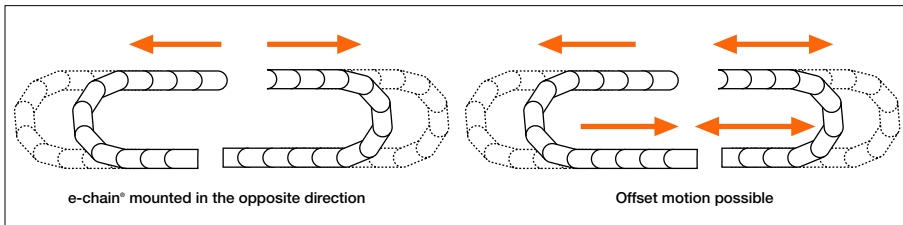

Virtually contactless energy supply for long travels -
low noise, low wear, safe and available!



levichain also available
as 2- and 3-strip e-chain*



Three-strip e-chain* assembled
with igus* chainflex*cables



Design levichain -
Schematic diagram of
the magnetic forces



- ❶ Modular igus* e-chain* different widths and bending radii
- ❷ Contactless guidance of upper run and (optional) lower run
- ❸ Support elements
- ❹ Magnet modules

Values for 1-, 2-, 3-strip e-chains*:

- Max. additional load 4 kg/m
- Travel: 40 m



Unsupported application for very long travels. The upper and lower runs are not laid on top of each other on long travels. The lower run can also be guided "floating" without contact. Max. additional load up to 4 kg/m. Travels up to 40 m possible.

Technical Data

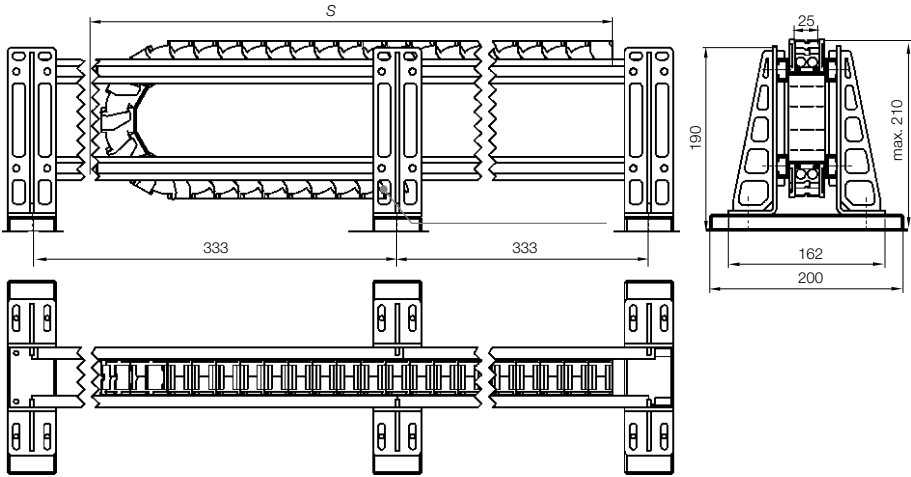

igus® levichain

Product Range

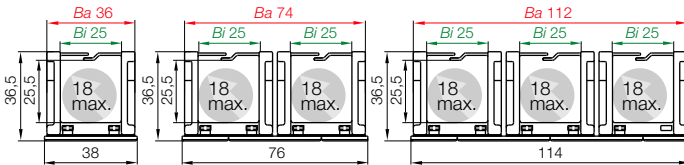

levichain - Dimensions

Part No.	Bi	Ba	hi	ha	R Bending radius
LV.25.25.....	25	36	25,5	36,5	045 063 075 100 125 150 175 200
LV.25.2/25.....	2 x 25	74	25,5	36,5	045 063 075 100 125 150 175 200
LV.25.3/25.....	3 x 25	112	25,5	36,5	045 063 075 100 125 150 175 200

Upon request - Delivery time: approx. 4-6 weeks after receipt of order!

LV 25. 3/25. 125. 1500. MM. RL



Part No. structure - levichain
LV.25.3/25.125.1500.MM*.RL

- Option RL: e-chain* counter run (e-chain* right and left)
- Magnetic module: M = Magnetic module / B = Delivery plate / MM = Magnetic module top/bottom / MB = Magnetic module top, delivery plate bottom
- Travel S: min. 1000 mm - in 25 mm steps
- Bending radius R
- 1-, 2-, 3-Band-e-chain* and inner width Bi
- Inner height hi
- Series: igus® levichain-System

Band-e-chain LV.25.3/25.125.1500.MM.RL -

levichain as 3-strip model and magnetic modules mounted top/bottom

*Please contact us if you need a different configuration.

igus[®] modular system for projects

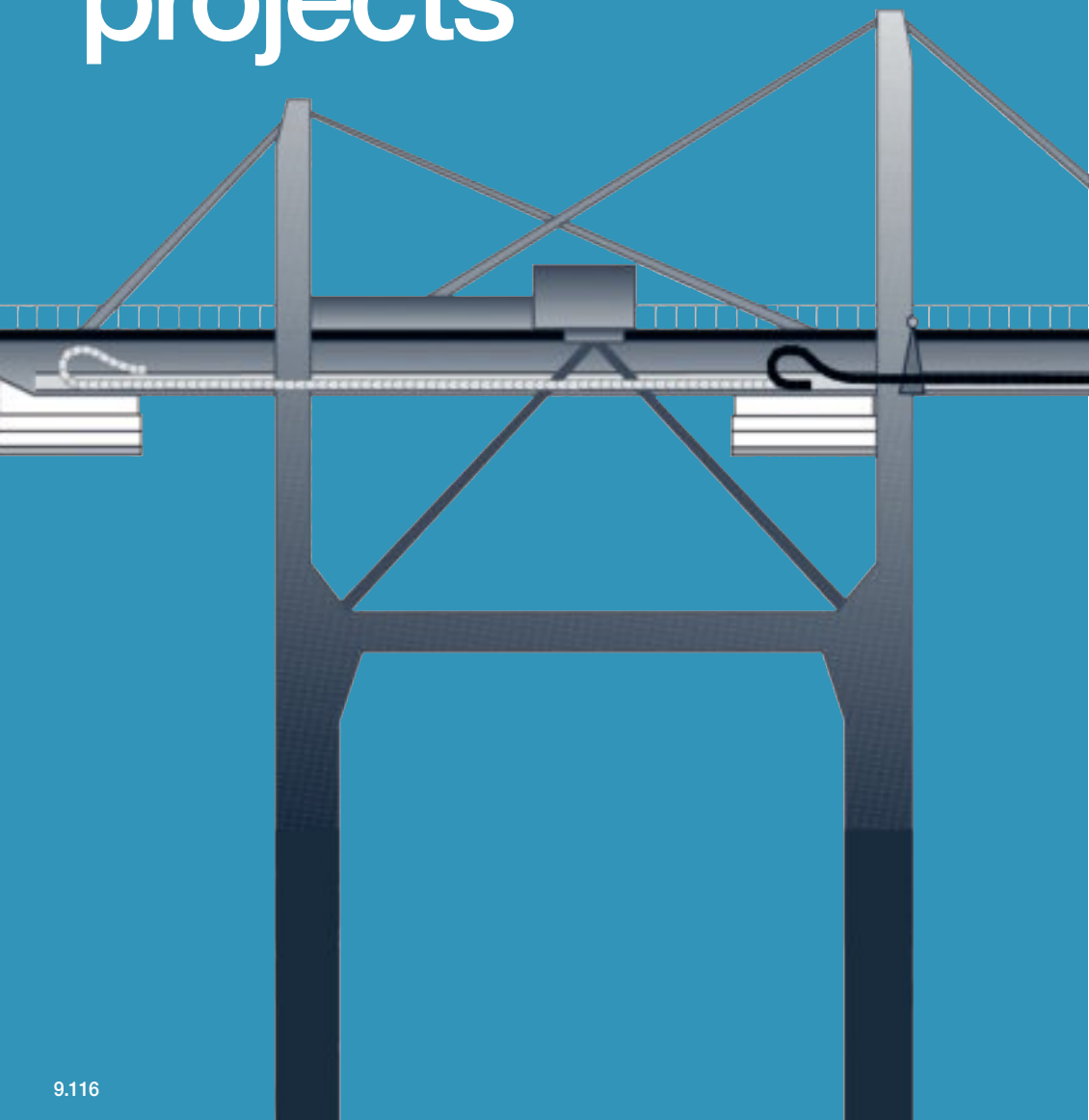

The igus® modular system for projects - special components, tested and time-proven in numerous projects, have now become available as a modular standard system.

- Faster quotations
- Faster project planning
- Detailed service manuals and documentation
- Time and cost savings
- Safe function
- System warranty available upon request, for individual applications

Available modules of such a modular system for projects entail, for example:

- PPDS tow arm with electronic push/pull force monitoring
- Fixation point modules for easy attachment of the e-chain® inside the guide trough, with no drilling required
- Extreme gliders gliding elements for even longer cycle life of e-chains® on long travels
- HD "heavy duty" trough systems from various materials and with different assembly kit designs, matching the respective application and stress levels

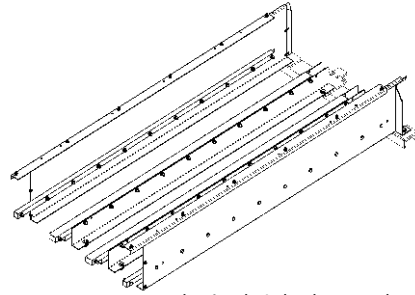

igus® project planning example, here: guide trough modules

Typical industries and applications

Cranes, offshore and many more

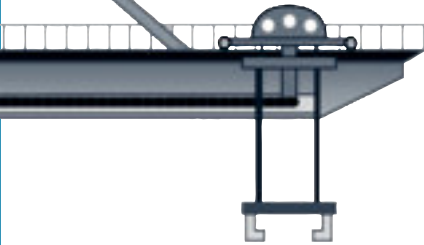

Long travels with electronics Push/Pull-force monitoring with the igus® PPDS System



igus® supervisors plan projects worldwide



Crane system designed by igus®